

Trimble® Precision-IQ™ Application for the TMX-2050™ Display

Version 4.0

Revision A

March 2016

Agriculture Business Area

10368 Westmoor Drive
Westminster, Colorado 80021
USA
800-361-1249 (toll free 800 215)
+1-937-245-5154 Phone
+1-937-233-9441 Fax
www.trimble.com
Email: trimble_support@trimble.com

Legal Notices

© 2016 Trimble Navigation Limited. All rights reserved.
Trimble, the Globe & Triangle logo, EZ-Boom, EZ-Guide, EZ-Pilot, EZ-Steer, FarmWorks Software, FmX, GreenSeeker, OmniSTAR, Trimble Ready, Tru Count Air Clutch, and WM-Drain are trademarks of Trimble Navigation Limited, registered in the United States and in other countries.
Autopilot, AutoSense, CenterPoint, CFX-750, Connected Farm, EZ-Remote, Farm Works, Farm Works Mapping, Farm Works Software, Field-IQ, FieldLevel, FM-750, FreeForm, LiquiBlock, NextSwath, Precision-IQ, Rawson, RTX, T3, TMX-2050, TrueGuide, TrueTracker, VRS Now, VRS, WM-Topo, XCN-2050, xFill, and Zephyr are trademarks of Trimble Navigation Limited.
For STL support, the software uses the Moscow Center for SPARC Technology adaptation of the SGI Standard Template Library. Copyright © 1994 Hewlett-Packard Company, Copyright © 1996, 97 Silicon Graphics Computer Systems, Inc., Copyright © 1997 Moscow Center for SPARC Technology.
Portions Copyright © 2009 Nokia Corporation and/or its subsidiary(-ies).
Portions Copyright © 2003, Bitstream Inc.
All other trademarks are the property of their respective owners.

Release Notice

This is the March2016 release (Revision A) of the Precision-IQ field application documentation. It applies to version 4.0 of the display software.

Legal Notices

The following limited warranties give you specific legal rights. You may have others, which vary from state/jurisdiction to state/jurisdiction.

Product Limited Warranty

Trimble warrants that this Trimble product and its internal components (the "Product") shall be free from defects in materials and workmanship and will substantially conform to Trimble's applicable published specifications for the Product for a period of one (1) year, starting from the earlier of (i) the date of installation, or (ii) six (6) months from the date of original Product shipment from Trimble. This warranty applies only to the Product if installed by Trimble or a dealer authorized by Trimble to perform Product installation services.

Software Components

All Product software components (sometimes hereinafter also referred to as "Software") are licensed solely for use as an integral part of the Product and are not sold. Any software accompanied by a separate end user license agreement ("EULA") shall be governed by the terms, conditions, restrictions and limited warranty terms of such EULA notwithstanding the preceding paragraph.
During the limited warranty period you will be entitled to receive such Fixes to the Product software that Trimble releases and makes commercially available and for which it does not charge separately, subject to the procedures for delivery to purchasers of Trimble products generally. If you have purchased the Product from an authorized Trimble dealer rather than from Trimble directly, Trimble may, at its option, forward the software Fix to the Trimble dealer for final distribution to you. Minor Updates, Major Upgrades, new products, or substantially new software releases, as identified by Trimble, are expressly excluded from this update process and limited warranty. Receipt of software Fixes or other enhancements shall not serve to extend the limited warranty period.
For purposes of this warranty the following definitions shall apply: (1) "Fix(es)" means an error correction or other update created to fix a previous software version that does not substantially conform to its Trimble specifications; (2) "Minor Update" occurs when enhancements are made to current features in a software program; and (3) "Major Upgrade" occurs when significant new features are added to software,

or when a new product containing new features replaces the further development of a current product line. Trimble reserves the right to determine, in its sole discretion, what constitutes a Fix, Minor Update, or Major Upgrade.

Gson components licensed under the Apache 2.0 License. The source is available from <http://code.google.com/p/google-gson/>. Google MVEL components licensed under the Apache 2.0 License. The source is available from <http://code.google.com/p/mvel.codehaouse.org>. Google Guava components listed under the Apache 2.0 License. The source is available from <http://code.google.com/p/guava-libraries>. MapQuest content licensed under the Open Data Commons Database License (DbCL). The source is available from <http://developer.mapquest.com>.
APACE LICENSE (Version 2.0, January 2004)

http://www.apache.org/licenses/TERMS_AND_CONDITIONS_FOR_USE,
REPRODUCTION, AND DISTRIBUTION

1. Definitions

"License" shall mean the terms and conditions for use, reproduction, and distribution as defined by Sections 1 through Section 9 of this document.

""License" shall mean the copyright owner or entity authorized by the copyright owner that is granting the License.

"Legal Entity" shall mean the union of the acting entity and all other entities that control, are controlled by, or are under common control with that entity. For the purposes of this definition, "control" means (i) the power, direct or indirect, to cause the direction or management of such entity, whether by contract or otherwise, or (ii) ownership of fifty percent (50%) or more of the outstanding shares, or (iii) beneficial ownership of such entity.

"You" (or "Your") shall mean an individual or Legal Entity exercising permissions granted by this License.

"Source" form shall mean the preferred form for making modifications, including but not limited to software source code, documentation source, and configuration files.

"Object" form shall mean any form resulting from mechanical transformation or translation of a Source form, including but not limited to compiled object code, generated documentation, and conversions to other media types.

"Work" shall mean the work of authorship, whether in Source or Object form, made available under the License, as indicated by a copyright notice that is included in or attached to the work (an example is provided in the Appendix below).

"Derivative Works" shall mean any work, whether in Source or Object form, that is based on (or derived from) the Work and for which the editorial revisions, annotations, elaborations, or other modifications represent, as a whole, an original work of authorship. For the purposes of this License, Derivative Works shall not include works that remain separable from, or merely link (or bind in name) to the interfaces of, the Work and Derivative Works thereof.

"Contribution" shall mean any work of authorship, including the original version of the Work and any modifications or additions to that Work or Derivative Works thereof, that is intentionally submitted to Licensor for inclusion in the Work by the copyright owner or by an individual or Legal Entity authorized to submit on behalf of the copyright owner. For the purposes of this definition, "submitted" means any form of electronic, verbal, or written communication sent to the Licensor or its representatives, including but not limited to communication on electronic mailing lists, source code control systems, and issue tracking systems that are managed by, or on behalf of, the Licensor for the purpose of discussing and improving the Work, but excluding communication that is conspicuously marked or otherwise designated in writing by the copyright owner as "Not a Contribution."

"Contributor" shall mean Licensor and any individual or Legal Entity on behalf of whom a Contribution has been received by Licensor and subsequently incorporated within the Work.

2. Grant of Copyright License. Subject to the terms and conditions of this License, each Contributor hereby grants to You a perpetual, worldwide, non-exclusive, no-charge, royalty-free, irrevocable copyright license to reproduce, prepare Derivative Works of, publicly display, publicly perform, sublicense, and distribute the Work and such Derivative Works in Source or Object form.

3. Grant of Patent License. Subject to the terms and conditions of this License, each Contributor hereby grants to You a perpetual, worldwide, non-exclusive, no-charge, royalty-free, irrevocable (except as stated in this section) patent license to make, have made, use, offer to sell, sell, import, and otherwise transfer the Work, where such license applies only to those patent claims licensable by such Contributor that are necessarily infringed by their Contribution(s) alone or by combination of their Contribution(s) with the Work to which such Contribution(s) was

submitted. If you institute patent litigation against any entity (including a cross-claim or counterclaim in a lawsuit) alleging that the Work or a Contribution incorporated within the Work constitutes direct or contributory patent infringement, then any patent licenses granted to You under this License for that Work shall terminate as of the date such litigation is filed.

4. Redistribution. You may reproduce and distribute copies of the Work or Derivative Works thereof in any medium, with or without modifications, and in Source or Object form, provided that You meet the following conditions:

You must give any other recipients of the Work or Derivative Works a copy of this License; and

You must cause any modified files to carry prominent notices stating that You changed the files; and

You must retain, in the Source form of any Derivative Works that You distribute, all copyright, patent, trademark, and attribution notices from the Source form of the Work, excluding those notices that do not pertain to any part of the Derivative Works; and

If the Work includes a "NOTICE" text file as part of its distribution, then any Derivative Works that You distribute must include a readable copy of the attribution notices contained within such NOTICE file, excluding those notices that do not pertain to any part of the Derivative Works, in at least one of the following places: within a NOTICE text file distributed as part of the Derivative Works; within the Source form or documentation, if provided along with the Derivative Works; or, within a display generated by the Derivative Works, if and wherever such third-party notices normally appear. The contents of the NOTICE file are for informational purposes only and do not modify the License. You may add Your own attribution notices within Derivative Works that You distribute, alongside or as an addendum to the NOTICE text from the Work, provided that such additional attribution notices cannot be construed as modifying the License.

You may add Your own copyright statement to Your modifications and may provide additional or different license terms and conditions for use, reproduction, or distribution of Your modifications, or for any such Derivative Works as a whole, provided Your use, reproduction, and distribution of the Work otherwise complies with the conditions stated in this License.

5. Submission of Contributions. Unless You explicitly state otherwise, any Contribution intentionally submitted for inclusion in the Work by You to the Licensor shall be under the terms and conditions of this License, without any additional terms or conditions. Notwithstanding the above, nothing herein shall supersede or modify the terms of any separate license agreement you may have executed with Licensor regarding such Contributions.

6. Trademarks. This License does not grant permission to use the trade names, trademarks, service marks, or product names of the Licensor, except as required for reasonable and customary use in describing the origin of the Work and reproducing the content of the NOTICE file.

7. Disclaimer of Warranty. Unless required by applicable law or agreed to in writing, Licensor provides the Work (and each Contributor provides its Contributions) on an "AS IS" BASIS, WITHOUT WARRANTIES OR CONDITIONS OF ANY KIND, either express or implied, including, without limitation, any warranties or conditions of TITLE, NON-INFRINGEMENT, MERCHANTABILITY, or FITNESS FOR A PARTICULAR PURPOSE. You are solely responsible for determining the appropriateness of using or redistributing the Work and assume any risks associated with Your exercise of permissions under this License.

8. Limitation of Liability. In no event and under no legal theory, whether in tort (including negligence), contract, or otherwise, unless required by applicable law (such as deliberate and grossly negligent acts) or agreed to in writing, shall any Contributor be liable to You for damages, including any direct, indirect, special, incidental, or consequential damages of any character arising as a result of this License or out of the use or inability to use the Work (including but not limited to damages for loss of goodwill, work stoppage, computer failure or malfunction, or any and all other commercial damages or losses), even if such Contributor has been advised of the possibility of such damages.

LWGL LICENSE

ODC DATABASE CONTENTS LICENSE

SGI FREE SOFTWARE LICENSE B (Version 2.0, Sept. 18, 2008)

Copyright © 2013 Silicon Graphics, Inc. All Rights Reserved.

Hierbij wordt toestemming gegeven aan elke persoon die een kopie van deze software en bijbehorende documentatiebestanden (de "Software") heeft verkregen, om gratis en zonder beperking in de Software te handelen, met inbegrip van, maar niet beperkt tot het recht om om kopieën van de Software te gebruiken, kopiëren, wijzigen, samenvoegen, publiceren, distribueren, in sub-licentie te geven en/of te

verkopen en dit toe te staan aan personen aan wie de Software is geleverd, met inachtneming van de volgende voorwaarden:

The above copyright notice including the dates of first publication and either this permission notice or a reference to

<http://oss.sgi.com/projects/FreeB/> shall be included in all copies or substantial portions of the Software.

DEZE SOFTWARE WORDT "AS IS" AANGEBODEN, ZONDER ENIGE GARANTIE, EXPLICIET OF IMPLICIET, MET INBEGRIJ VAN MAAR NIET BEPERKT TOT, ENIGE GARANTIE VAN WEDERVERKOOPBAARHEID, GESCHIKTHEID VOOR EEN BEPAALD DOEL EN NIET-SCHENDING. IN NO EVENT SHALL SILICON GRAPHICS, INC. BE LIABLE FOR ANY CLAIM, DAMAGES OR OTHER LIABILITY, WHETHER IN AN ACTION OF CONTRACT, TORT OR OTHERWISE, ARISING FROM, OUT OF OR IN CONNECTION WITH THE SOFTWARE OR THE USE OR OTHER DEALINGS IN THE SOFTWARE.

Except as contained in this notice, the name of Silicon Graphics, Inc. shall not be used in advertising or otherwise to promote the sale, use or other dealings in this Software without prior written authorization from Silicon Graphics, Inc.

MAPQUEST PLATFORM TERMS OF USE (Last Updated: November 1, 2011)

Community Edition License Agreement

INTRODUCTION. MapQuest has been helping people find places and get maps and directions for over 40 years. We make the MapQuest APIs, our Open Services (as described at <http://open.mapquestapi.com/>), Community Accounts and other developer services (in short, the "MapQuest Services"), along with the maps, driving directions and other content delivered through the MapQuest Services (the "MapQuest Content"), available without charge to encourage developers to use these services and content in developing their applications and websites. We want you to be creative and build awesome applications and websites that thrill your users. All we ask is that you comply with the terms that are included in these Terms of Use.

We will provide the developer community at-large with support in various forms, such as forums, blog posts or FAQs. Since we're providing the MapQuest Services for free, we don't provide individual technical support or warranties for the Community Services, but if you want to receive technical support and warranties, we have a product for you. Please check out our MapQuest Platform Services Enterprise Edition and learn more about the services we will provide for reasonable fees.

If you choose to use any of the MapQuest Services or if you set up a Community Account, you are agreeing to abide by these Terms of Use and are forming an agreement between yourself and MapQuest, Inc. ("MapQuest"). If you do not want to abide by these Terms of Use, then don't use the MapQuest Services.

LICENSES FROM MAPQUEST TO YOU.

2.1. MapQuest Services License. MapQuest grants you a non-exclusive, non-assignable, non-sublicensable, revocable limited license to use the MapQuest Services during the Term of these Terms of Use as provided by MapQuest in the manner permitted in these Terms of Use.

2.2. MapQuest Content License. MapQuest grants you a non-exclusive, non-assignable, non-sublicensable, revocable limited license access, use, publicly perform and publicly display the MapQuest Content as the MapQuest Content is provided through the MapQuest Services and in the manner permitted by these Terms of Use.

GENERAL RESTRICTIONS, ADDITIONAL LEGAL NOTICE, RESERVATION OF RIGHTS.

3.1. Restrictions. Except as expressly authorized by MapQuest, You must not:

decompile, disassemble, reverse engineer, or otherwise attempt to derive any source code from the MapQuest Services or MapQuest Content, other than the Open Services;
interfere or disrupt MapQuest servers or networks, or disobey any network access or security requirements, policies, procedures or regulations of MapQuest (including the enabling of any viruses, Trojan horses, trap doors, back doors, worms, time bombs, cancelbots, adware, spyware or other computer programming routines designed or intended to damage, detrimentally interfere with, surreptitiously intercept or expropriate any system, data or personal information);
use the MapQuest Services as a means to engage in conduct that reflects poorly upon, disparages or devalues MapQuest's reputation or goodwill, as determined in MapQuest's sole discretion;
use the MapQuest Services, other than the Open Services, in conjunction with any commercial application not publicly available without charge (other than mobile applications for which users pay a fee to download/install the application). If your application does not fit this

criteria and you would like to discuss additional options for using the MapQuest Services please contact info@mapquest.com; use the MapQuest Services, other than the Open Services, to process or generate data for any third party (other than for end users as expressly permitted hereunder);

use the MapQuest Services with any content or product that falsely expresses or implies that such content or product is sponsored or endorsed by MapQuest;

use the MapQuest Services in conjunction with a site or application which contains or displays adult content or promotes illegal activities, gambling, or the sale of tobacco or alcohol to persons under twenty-one (21) years of age;

3.2. Additional Legal Requirements. In addition to the restrictions set forth in Section 3.1, your use of the MapQuest Services and MapQuest Content is subject to the Additional Legal Requirements which are incorporated and made a part of these Terms of Use. Please read the Additional Legal Requirements carefully as they include usage limits and additional restrictions that may impact your plans for development.

3.3. Reservation of Rights. MapQuest reserves all rights not expressly granted in these Terms of Use and you may not use the MapQuest Services or MapQuest Content in any manner not expressly authorized in these Terms of Use.

LICENSE FROM YOU TO MAPQUEST. If you upload any data, feedback, ideas, suggestions, content, points of interest (including any points of interest that include Trademarks) or other material to MapQuest (collectively "Your Content"), you hereby grant MapQuest a perpetual, worldwide, non-exclusive, royalty-free license to access, archive, reproduce, publicly display, translate, modify the format or the display of, distribute, transmit, stream, cache, overlay, seam, perform, sublicense, and otherwise use Your Content with or without attribution and without financial obligation, in whole or in part, via any method for any purpose. MapQuest makes no assertion of ownership over Your Content, and you retain all intellectual property rights to Your Content, subject to the license you grant to MapQuest above.

MODIFICATIONS TO THESE TERMS OF USE AND THE SERVICES.

MapQuest reserves the right to change or modify these Terms of Use, the MapQuest Services and/or the MapQuest Content. Please check these Terms of Use, including the Additional Legal Requirements periodically for changes. Your continued use of the MapQuest Services or MapQuest Content following the posting of any changes to the Terms of Use constitutes acceptance of those changes.

TERMINATION. MapQuest may terminate these Terms of Use and/or the provision of the MapQuest Services or MapQuest Content at any time, for any reason, with or without notice.

PRIVACY POLICY AND END USER TERMS.

7.1. Privacy Policy. MapQuest's collection and use of personally identifiable information is governed by the AOL Network Privacy Policy, available at http://about.aol.com/aolnetwork/aol_pp.

7.2. End User Terms. End users shall only be entitled to use the MapQuest Services and MapQuest Content if they accept the then current end user Terms of Use located at <http://info.mapquest.com/terms-of-use/>. MapQuest reserves the right to amend and/or replace these terms and the form and manner of presentation. You must provide a hypertext link at the bottom of each page in your website or application where the MapQuest Services or MapQuest Content can be viewed or accessed, or within the terms of use of your application or website, to the end user terms of use.

ACCESS AND USAGE DATA.

8.1. Credentials. MapQuest, at its discretion, may require you to create an account and obtain an access key and other related credentials (collectively "Credentials") to use the MapQuest Services or certain aspects of the MapQuest Services. You are responsible for maintaining the confidentiality of your Credentials and for any usage or abuse of the MapQuest Services or MapQuest Content by anyone using your Credentials.

8.2. Usage Data. MapQuest's servers record information when you visit MapQuest websites or when applications and/or Credentials call or invoke the MapQuest Services. This information may include, without limitation, the URL, IP address, browser type, Credential and access times and dates. MapQuest may use this information to promote, operate, and improve MapQuest services, products and properties.

PROPRIETARY RIGHTS. You acknowledge and agree the MapQuest Services and MapQuest Content are works for purposes of copyright law, and embody valuable, confidential, trade secret information of MapQuest, the development of which required the expenditure of substantial time and money. As between MapQuest and You, MapQuest retains exclusive ownership of any and all rights, title and interest (including all intellectual property rights) in the MapQuest

Services and MapQuest Content, and you shall not acquire any rights, express or implied, in the foregoing by virtue of these Terms of Use other than otherwise expressly set forth. For purposes of these Terms of Use, the term "Trademarks" means all trademarks, trade names, service marks, logos, domain names, along with any other distinctive brand features of MapQuest or its suppliers. All use by You of Trademarks shall inure to the benefit of MapQuest. Further, You shall not (a) display a Trademark as the most prominent element on any page of Your website, application or paper map; (b) display a Trademark in a manner that is misleading, defamatory, infringing, libelous, disparaging, obscene or otherwise objectionable to MapQuest as determined by MapQuest in its sole discretion; or (c) remove, distort or alter any element of a Trademark.

DISCLAIMER OF WARRANTIES. THE MAPQUEST SERVICES AND MAPQUEST CONTENT ARE PROVIDED ON AN "AS IS" AND "AS AVAILABLE" BASIS. MAPQUEST DISCLAIMS ANY AND ALL WARRANTIES, WHETHER EXPRESS OR IMPLIED, INCLUDING BUT NOT LIMITED TO ANY WARRANTIES OF MERCHANTABILITY, FITNESS FOR A PARTICULAR PURPOSE, ACCURACY OR NON-INFRINGEMENT. MAPQUEST DOES NOT REPRESENT OR WARRANT THAT THE MAPQUEST SERVICES OR CONTENT, OR ANY PORTION THEREOF, IS OR WILL BE FREE OF DEFECTS OR ERRORS (OR THAT ANY SUCH DEFECTS OR ERRORS WILL BE CORRECTED), VIRUS FREE, ABLE TO OPERATE ON AN UNINTERRUPTED BASIS, MEET YOUR REQUIREMENTS, OR CAPABLE OF BEING INTEGRATED INTO OR WITH YOUR COMPUTER SYSTEM, APPLICATIONS OR NETWORK. FURTHER, MAPQUEST DOES NOT WARRANT OR MAKE ANY REPRESENTATIONS REGARDING THE USE OR THE RESULTS OF THE USE OF THE MAPQUEST SERVICES, OR ANY PORTION THEREOF, IN TERMS OF ITS CORRECTNESS, ACCURACY, QUALITY, RELIABILITY, OR OTHERWISE. THIS DISCLAIMER CONSTITUTES AN ESSENTIAL PART OF THESE TERMS OF USE. IF THIS EXCLUSION IS HELD UNENFORCEABLE, THEN ALL EXPRESS AND IMPLIED WARRANTIES SHALL BE LIMITED IN DURATION TO A PERIOD OF FIFTEEN (15) DAYS AFTER THE EFFECTIVE DATE, AND NO WARRANTIES SHALL APPLY AFTER THAT PERIOD.

LIMITATION ON LIABILITY. NEITHER MAPQUEST NOR ITS AFFILIATES NOR ANY OF THEIR SUPPLIERS SHALL BE LIABLE TO YOU OR ANY OTHER THIRD PARTY FOR ANY DIRECT, INDIRECT, SPECIAL, INCIDENTAL OR CONSEQUENTIAL DAMAGES OF ANY NATURE ARISING OUT OF THE POSSESSION OF, ACCESS TO, USE OF, OR INABILITY TO ACCESS OR USE THE MAPQUEST SERVICES OR MAPQUEST CONTENT, OR ANY PORTION, INCLUDING, WITHOUT LIMITATION, LOST PROFITS, DATA LOSS, COST OF PROCUREMENT FOR SUBSTITUTE GOODS, OR COMPUTER FAILURE OR MALFUNCTION, EVEN IF MAPQUEST HAS BEEN ADVISED OF THE POSSIBILITY OF SUCH DAMAGES, AND REGARDLESS OF WHETHER THE CLAIM OR LIABILITY IS BASED UPON ANY CONTRACT, TORT, BREACH OF WARRANTY OR OTHER LEGAL OR EQUITABLE THEORY. IN NO EVENT SHALL MAPQUEST'S TOTAL AGGREGATE LIABILITY UNDER THESE TERMS OF USE EXCEED THE LESSER OF (A) THE TOTAL AMOUNT OF FEES PAID BY YOU TO MAPQUEST UNDER THESE TERMS OF USE FOR THE TWELVE (12) MONTHS PRECEDING THE DATE OF THE EVENT GIVING RISE TO SUCH CLAIM; OR (B) FIVE HUNDRED DOLLARS (\$500).

YOU EXPRESSLY ACKNOWLEDGE AND AGREE THAT THE PARTICIPATION IN AND USE OF THE MAPQUEST SERVICES AND MAPQUEST CONTENT IS DONE AT YOUR OWN RISK AND THAT YOU ARE SOLELY RESPONSIBLE AND LIABLE FOR ANY DAMAGE SUSTAINED TO YOUR COMPUTER SYSTEM, NETWORK OR DATA RESULTING FROM SUCH PARTICIPATION OR USE.

SOME JURISDICTIONS DO NOT ALLOW THE EXCLUSION OF CERTAIN WARRANTIES OR THE LIMITATION OR EXCLUSION OF LIABILITY FOR INCIDENTAL OR CONSEQUENTIAL DAMAGES.

INDEMNITY. You agree to indemnify, defend and hold MapQuest and its affiliates, and each of their officers, directors, employees, agents, co-branders or other partners (as well as each of their suppliers), successors and permitted assigns ("Indemnified Parties") harmless from and against any third party claim or action, including any liability, cost, losses, damages, expenses, and attorney's fees, arising from or in any way related to Your access, use or participation in the MapQuest Services (including claims related to Your Content and any use of the MapQuest Services with software, data, content, systems, or other technology not provided by MapQuest), any violation of these Terms of Use, or any alleged infringement of a patent, copyright, trademark, trade secret, or other intellectual property right. MapQuest shall use good faith efforts to provide you with prompt notice of any such claim or action; provided however, you agree that, upon MapQuest's written request, MapQuest shall control the defense or settlement of any such claim or action and you shall provide reasonable cooperation to MapQuest. You may not

settle an indemnifiable claim without obtain MapQuest's prior written consent.

EXPORT RESTRICTIONS. You agree to comply with all export and import laws and restrictions and regulations of the United States or any foreign agency or authority, and not to export or re-export MapQuest Services or any direct product thereof in violation of any such restrictions, laws or regulations, or without all necessary approvals.

NOTICES AND TRANSACTING ELECTRONICALLY. You understand and agree that MapQuest is an online service and that you are transacting with MapQuest electronically. MapQuest shall provide electronic notices by posting them on this website and/or by sending an email to any account associated with your Credentials.

GENERAL PROVISIONS.

15.1. Entire Agreement. These Terms of Use constitute the entire agreement between MapQuest and You with respect to the subject matter of these Terms of Use, and supersedes all prior agreements, understandings and communications between MapQuest and You with respect to such subject matter. No modification or amendment to these Terms of Use shall be effective unless in writing by MapQuest.

15.2. Choice of Law; Jurisdiction. These Terms of Use are made under and shall be governed by and construed in accordance with the laws of the Commonwealth of Virginia (except for its conflicts of laws principles) and specifically excluding f the United Nations Convention on Contracts for the International Sale of Goods. MapQuest and You expressly agree that exclusive jurisdiction for any claim or dispute relating to or arising out of these Terms of Use resides in the state courts in Loudoun County, Virginia and the federal courts of the Eastern District of Virginia (Alexandria Division) and further agree and expressly consent to the exercise of personal jurisdiction in such state and federal courts of Virginia in connection with any such dispute.

15.3. Severability; Waiver. If any provision in these Terms of Use should be held illegal or unenforceable by a court having jurisdiction, such provision shall be modified to the extent necessary to render it enforceable without losing its intent, or severed from these Terms of Use if no such modification is possible, and other provisions of these Terms of Use shall remain in full force and effect. A waiver by either MapQuest or You (as applicable) of any term or condition of these Terms of Use or any breach thereof, in any one instance, shall not waive such term or condition or any subsequent breach thereof.

15.4. Public Statements. You acknowledge and agree that MapQuest may make any public statements regarding the existence of these Terms of Use or the relationship described herein, without Your consent.

15.5. Survival. Any term or condition of these Terms of Use that by its nature would logically survive termination or expiration of these Terms of Use, including but not limited to protections of proprietary rights, indemnifications, and limitations of liability, shall survive such termination or expiration.

15.6. Independent Contractors. The parties to these Terms of Use are independent contractors. Neither party is an agent, representative or partner of the other party. Neither party shall have any right, power or authority to enter into any agreement for or on behalf of, or incur any obligation or liability of, or otherwise to bind, the other party.

15.7. Equitable Remedies. You acknowledge and agree that monetary damages may be insufficient to compensate MapQuest for an actual or anticipated breach of these Terms of Use by you. You agree that in such circumstances MapQuest shall be entitled to seek equitable remedies (including preliminary and permanent injunctions), in addition to any other remedies available to MapQuest at law or hereunder.

15.8. Statute of Limitations. You agree that regardless of any statute or law to the contrary, any claim or cause of action arising out of or related to use of the MapQuest Services or these Terms of Use must be filed by you within one (1) year after such claim or cause of action arose or be forever barred.

15.9. Consent to Further Contacts. You agree that MapQuest may contact You with respect to these Terms of Use, any other MapQuest products and services, and in relation to any marketing related purposes.

ODC Open Database License (ODbL)

The Open Database License (ODbL) is a license agreement intended to allow users to freely share, modify, and use this Database while maintaining this same freedom for others. Many databases are covered by copyright, and therefore this document licenses these rights. Some jurisdictions, mainly in the European Union, have specific rights that cover databases, and so the ODbL addresses these rights, too. Finally, the ODbL is also an agreement in contract for users of this Database to act in certain ways in return for accessing this Database.

Databases can contain a wide variety of types of content (images, audiovisual material, and sounds all in the same database, for example),

and so the ODbL only governs the rights over the Database, and not the contents of the Database individually. Licensors should use the ODbL together with another license for the contents, if the contents have a single set of rights that uniformly covers all of the contents. If the contents have multiple sets of different rights, Licensors should describe what rights govern what contents together in the individual record or in some other way that clarifies what rights apply.

Sometimes the contents of a database, or the database itself, can be covered by other rights not addressed here (such as private contracts, trade mark over the name, or privacy rights / data protection rights over information in the contents), and so you are advised that you may have to consult other documents or clear other rights before doing activities not covered by this License.

The Licensor (as defined below) and You (as defined below) agree as follows:

1.0 Definitions of Capitalised Words

"Collective Database" – Means this Database in unmodified form as part of a collection of independent databases in themselves that together are assembled into a collective whole. A work that constitutes a Collective Database will not be considered a Derivative Database.

"Convey" – As a verb, means Using the Database, a Derivative Database, or the Database as part of a Collective Database in any way that enables a Person to make or receive copies of the Database or a Derivative Database. Conveying does not include interaction with a user through a computer network, or creating and Using a Produced Work, where no transfer of a copy of the Database or a Derivative Database occurs.

"Contents" – The contents of this Database, which includes the information, independent works, or other material collected into the Database. For example, the contents of the Database could be factual data or works such as images, audiovisual material, text, or sounds.

"Database" – A collection of material (the Contents) arranged in a systematic or methodical way and individually accessible by electronic or other means offered under the terms of this License.

"Database Directive" – Means Directive 96/9/EC of the European Parliament and of the Council of 11 March 1996 on the legal protection of databases, as amended or succeeded.

"Database Right" – Means rights resulting from the Chapter III ("suigeneris") rights in the Database Directive (as amended and as transposed by member states), which includes the Extraction and Re-utilisation of the whole or a Substantial part of the Contents, as well as any similar rights available in the relevant jurisdiction under Section 10.4.

"Derivative Database" – Means a database based upon the Database, and includes any translation, adaptation, arrangement, modification, or any other alteration of the Database or of a Substantial part of the Contents. This includes, but is not limited to, Extracting or Re-utilising the whole or a Substantial part of the Contents in a new Database.

"Extraction" – Means the permanent or temporary transfer of all or a Substantial part of the Contents to another medium by any means or in any form.

"License" – Means this license agreement and is both a license of rights such as copyright and Database Rights and an agreement in contract.

"Licensor" – Means the Person that offers the Database under the terms of this License.

"Person" – Means a natural or legal person or a body of persons corporate or incorporate.

"Produced Work" – a work (such as an image, audiovisual material, text, or sounds) resulting from using the whole or a Substantial part of the Contents (via a search or other query) from this Database, a Derivative Database, or this Database as part of a Collective Database.

"Publicly" – means to Persons other than You or under Your control by either more than 50% ownership or by the power to direct their activities (such as contracting with an independent consultant).

"Re-utilisation" – means any form of making available to the public all or a Substantial part of the Contents by the distribution of copies, by renting, by online or other forms of transmission.

"Substantial" – Means substantial in terms of quantity or quality or a combination of both. The repeated and systematic Extraction or Re-utilisation of insubstantial parts of the Contents may amount to the Extraction or Re-utilisation of a Substantial part of the Contents.

"Use" – As a verb, means doing any act that is restricted by copyright or Database Rights whether in the original medium or any other; and includes without limitation distributing, copying, publicly performing, publicly displaying, and preparing derivative works of the Database, as well as modifying the Database as may be technically necessary to use it in a different mode or format.

"You" – Means a Person exercising rights under this License who has not previously violated the terms of this License with respect to the Database, or who has received express permission from the Licensor to exercise rights under this License despite a previous violation. Words in the singular include the plural and vice versa.

2.0 What this License covers

2.1. Legal effect of this document. This License is:

- a. A license of applicable copyright and neighbouring rights;
- b. A license of the Database Right; and
- c. An agreement in contract between You and the Licensor.

2.2 Legal rights covered. This License covers the legal rights in the Database, including:

- a. Copyright. Any copyright or neighbouring rights in the Database. The copyright licensed includes any individual elements of the Database, but does not cover the copyright over the Contents independent of this Database. See Section 2.4 for details. Copyright law varies between jurisdictions, but is likely to cover: the Database model or schema, which is the structure, arrangement, and organization of the Database, and can also include the Database tables and table indexes; the data entry and output sheets; and the Field names of Contents stored in the Database;
- b. Database Rights. Database Rights only extend to the Extraction and Re-utilisation of the whole or a Substantial part of the Contents. Database Rights can apply even when there is no copyright over the Database. Database Rights can also apply when the Contents are removed from the Database and are elected and arranged in a way that would not infringe any applicable copyright; and
- c. Contract. This is an agreement between You and the Licensor for access to the Database. In return you agree to certain conditions of use on this access as outlined in this License.

2.3 Rights not covered.

- a. This License does not apply to computer programs used in the making or operation of the Database;
- b. This License does not cover any patents over the Contents or the Database; and
- c. This License does not cover any trademarks associated with the Database.

2.4 Relationship to Contents in the Database. The individual items of the Contents contained in this Database may be covered by other rights, including copyright, patent, data protection, privacy, or personality rights, and this License does not cover any rights (other than Database Rights or in contract) in individual Contents contained in the Database. For example, if used on a Database of images (the Contents), this License would not apply to copyright over individual images, which could have their own separate licenses, or one single license covering all of the rights over the images.

3.0 Rights granted

3.1 Subject to the terms and conditions of this License, the Licensor grants to You a worldwide, royalty-free, non-exclusive, terminable (but only under Section 9) license to Use the Database for the duration of any applicable copyright and Database Rights. These rights explicitly include commercial use, and do not exclude any field of endeavour. To the extent possible in the relevant jurisdiction, these rights may be exercised in all media and formats whether now known or created in the future. The rights granted cover, for example:

- a. Extraction and Re-utilisation of the whole or a Substantial part of the Contents;
- b. Creation of Derivative Databases;
- c. Creation of Collective Databases;
- d. Creation of temporary or permanent reproductions by any means and in any form, in whole or in part, including of any Derivative Databases or as a part of Collective Databases; and
- e. Distribution, communication, display, lending, making available, or performance to the public by any means and in any form, in whole or in part, including of any Derivative Database or as a part of Collective Databases.

3.2 Compulsory license schemes. For the avoidance of doubt:

- a. Non-waivable compulsory license schemes. In those jurisdictions in which the right to collect royalties through any statutory or compulsory licensing scheme cannot be waived, the Licensor reserves the exclusive right to collect such royalties for any exercise by You of the rights granted under this License;
- b. Waivable compulsory license schemes. In those jurisdictions in which the right to collect royalties through any statutory or compulsory licensing scheme can be waived, the Licensor waives the exclusive right to collect such royalties for any exercise by You of the rights granted under this License; and
- c. Voluntary license schemes. The Licensor waives the right to collect royalties, whether individually or, in the event that the Licensor is a

member of a collecting society that administers voluntary licensing schemes, via that society, from any exercise by You of the rights granted under this License.

3.3 The right to release the Database under different terms, or to stop distributing or making available the Database, is reserved. Note that this Database may be multiple-licensed, and so You may have the choice of using alternative licenses for this Database. Subject to Section 10.4, all other rights not expressly granted by Licensor are reserved.

4.0 Conditions of Use

4.1 The rights granted in Section 3 above are expressly made subject to Your complying with the following conditions of use. These are important conditions of this License, and if You fail to follow them, You will be in material breach of its terms.

4.2 Notices. If You Publicly Convey this Database, any Derivative Database, or the Database as part of a Collective Database, then You must:

- a. Do so only under the terms of this License or another license permitted under Section 4.4;
 - b. Include a copy of this License (or, as applicable, a license permitted under Section 4.4) or its Uniform Resource Identifier (URI) with the Database or Derivative Database, including both in the Database or Derivative Database and in any relevant documentation; and
 - c. Keep intact any copyright or Database Right notices and notices that refer to this License.
- d. If it is not possible to put the required notices in a particular file due to its structure, then You must include the notices in a location (such as a relevant directory) where users would be likely to look for it.

4.3 Notice for using output (Contents). Creating and Using a Produced Work does not require the notice in Section 4.2. However, if you Publicly Use a Produced Work, You must include a notice associated with the Produced Work reasonably calculated to make any Person that uses, views, accesses, interacts with, or is otherwise exposed to the Produced Work aware that Content was obtained from the Database, Derivative Database, or the Database as part of a Collective Database, and that it is available under this License.

a. Example notice. The following text will satisfy notice under Section 4.3: Contains information from DATABASE NAME, which is made available here under the Open Database License (ODbL). DATABASE NAME should be replaced with the name of the Database and a hyperlink to the URI of the Database. "Open Database License" should contain a hyperlink to the URI of the text of this License. If hyperlinks are not possible, You should include the plain text of the required URI's with the above notice.

4.4 Share alike.

a. Any Derivative Database that You Publicly Use must be only under the terms of:

- i. This License;
- ii. A later version of this License similar in spirit to this License; or
- iii. A compatible license.

If You license the Derivative Database under one of the licenses mentioned in (iii), You must comply with the terms of that license.

b. For the avoidance of doubt, Extraction or Re-utilisation of the whole or a Substantial part of the Contents into a new database is a Derivative Database and must comply with Section 4.4.

c. Derivative Databases and Produced Works. A Derivative Database is Publicly Used and so must comply with Section 4.4. If a Produced Work created from the Derivative Database is Publicly Used.

d. Share Alike and additional Contents. For the avoidance of doubt, You must not add Contents to Derivative Databases under Section 4.4 that are incompatible with the rights granted under this License.

e. Compatible licenses. Licensors may authorise a proxy to determine compatible licenses under Section 4.4 a iii. If they do so, the authorised proxy's public statement of acceptance of a compatible license grants You permission to use the compatible license.

4.5 Limits of Share Alike. The requirements of Section 4.4 do not apply in the following:

- a. For the avoidance of doubt, You are not required to license Collective Databases under this License if You incorporate this Database or a Derivative Database in the collection, but this License still applies to this Database or a Derivative Database as a part of the Collective Database;
- b. Using this Database, a Derivative Database, or this Database as part of a Collective Database to create a Produced Work does not create a Derivative Database for purposes of Section 4.4; and
- c. Use of a Derivative Database internally within an organisation is not to the public and therefore does not fall under the requirements of Section 4.4.

4.6 Access to Derivative Databases. If You Publicly Use a Derivative Database or a Produced Work from a Derivative Database,

You must also offer to recipients of the Derivative Database or Produced Work a copy in a machine readable form of:

- a. The entire Derivative Database; or
 - b. A file containing all of the alterations made to the Database or the method of making the alterations to the Database (such as an algorithm), including any additional Contents, that make up all the differences between the Database and the Derivative Database. The Derivative Database (under a.) or alteration file (under b.) must be available at no more than a reasonable production cost for physical distributions and free of charge if distributed over the internet.
- 4.7 Technological measures and additional terms
- a. This License does not allow You to impose (except subject to Section 4.7 b.) any terms or any technological measures on the Database, a Derivative Database, or the whole or a Substantial part of the Contents that alter or restrict the terms of this License, or any rights granted under it, or have the effect or intent of restricting the ability of any person to exercise those rights.
 - b. Parallel distribution. You may impose terms or technological measures on the Database, a Derivative Database, or the whole or a Substantial part of the Contents (a "Restricted Database") in contravention of Section 4.74 a. only if You also make a copy of the Database or a Derivative Database available to the recipient of the Restricted Database:
 - i. That is available without additional fee;
 - ii. That is available in a medium that does not alter or restrict the terms of this License, or any rights granted under it, or have the effect or intent of restricting the ability of any person to exercise those rights (an "Unrestricted Database"); and
 - iii. The Unrestricted Database is at least as accessible to the recipient as a practical matter as the Restricted Database.
 - c. For the avoidance of doubt, You may place this Database or a Derivative Database in an authenticated environment, behind a password, or within a similar access control scheme provided that You do not alter or restrict the terms of this License or any rights granted under it or have the effect or intent of restricting the ability of any person to exercise those rights.

4.8 Licensing of others. You may not sublicense the Database. Each time You communicate the Database, the whole or Substantial part of the Contents, or any Derivative Database to anyone else in any way, the Licensor offers to the recipient a license to the Database on the same terms and conditions as this License. You are not responsible for enforcing compliance by third parties with this License, but You may enforce any rights that You have over a Derivative Database. You are solely responsible for any modifications of a Derivative Database made by You or another Person at Your direction. You may not impose any further restrictions on the exercise of the rights granted or affirmed under this License.

5.0 Moral rights

5.1 Moral rights. This section covers moral rights, including any rights to be identified as the author of the Database or to object to treatment that would otherwise prejudice the author's honour and reputation, or any other derogatory treatment:

- a. For jurisdictions allowing waiver of moral rights, Licensor waives all moral rights that Licensor may have in the Database to the fullest extent possible by the law of the relevant jurisdiction under Section 10.4;
 - b. If waiver of moral rights under Section 5.1 a in the relevant jurisdiction is not possible, Licensor agrees not to assert any moral rights over the Database and waives all claims in moral rights to the fullest extent possible by the law of the relevant jurisdiction under Section 10.4; and
 - c. For jurisdictions not allowing waiver or an agreement not to assert moral rights under Section 5.1 a and b, the author may retain their moral rights over certain aspects of the Database. Please note that some jurisdictions do not allow for the waiver of moral rights, and so moral rights may still subsist over the Database in some jurisdictions.
- 6.0 Fair dealing, Database exceptions, and other rights not affected
- 6.1 This License does not affect any rights that You or anyone else may independently have under any applicable law to make any use of this Database, including without limitation:

- a. Exceptions to the Database Right including: Extraction of Contents from non-electronic Databases for private purposes, Extraction for purposes of illustration for teaching or scientific research, and Extraction or Re-utilisation for public security or an administrative or judicial procedure.
- b. Fair dealing, fair use, or any other legally recognised limitation or exception to infringement of copyright or other applicable laws.

6.2 This License does not affect any rights of lawful users to Extract and Re-utilise insubstantial parts of the Contents, evaluated quantitatively or qualitatively, for any purposes whatsoever, including creating a

Derivative Database (subject to other rights over the Contents, see Section 2.4). The repeated and systematic Extraction or Re-utilisation of insubstantial parts of the Contents may however amount to the Extraction or Re-utilisation of a Substantial part of the Contents.

7.0 Warranties and Disclaimer
7.1 The Database is licensed by the Licensor "as is" and without any warranty of any kind, either express, implied, or arising by statute, custom, course of dealing, or trade usage. Licensor specifically disclaims any and all implied warranties or conditions of title, non-infringement, accuracy or completeness, the presence or absence of errors, fitness for a particular purpose, merchantability, or otherwise.

Some jurisdictions do not allow the exclusion of implied warranties, so this exclusion may not apply to You.

8.0 Limitation of liability

8.1 Subject to any liability that may not be excluded or limited by law, the Licensor is not liable for, and expressly excludes, all liability for loss or damage however and whenever caused to anyone by any use under this License, whether by You or by anyone else, and whether caused by any fault on the part of the Licensor or not. This exclusion of liability includes, but is not limited to, any special, incidental, consequential, punitive, or exemplary damages such as loss of revenue, data, anticipated profits, and lost business. This exclusion applies even if the Licensor has been advised of the possibility of such damages.

8.2 If liability may not be excluded by law, it is limited to actual and direct financial loss to the extent it is caused by proved negligence on the part of the Licensor.

9.0 Termination of Your rights under this License

9.1 Any breach by You of the terms and conditions of this License automatically terminates this License with immediate effect and without notice to You. For the avoidance of doubt, Persons who have received the Database, the whole or a Substantial part of the Contents, Derivative Databases, or the Database as part of a Collective Database from You under this License will not have their licenses terminated provided their use is in full compliance with this License or a license granted under Section 4.8 of this License. Sections 1, 2, 7, 8, 9 and 10 will survive any termination of this License.

9.2 If You are not in breach of the terms of this License, the Licensor will not terminate Your rights under it.

9.3 Unless terminated under Section 9.1, this License is granted to You for the duration of applicable rights in the Database.

9.4 Reinstatement of rights. If you cease any breach of the terms and conditions of this License, then your full rights under this License will be reinstated:

- a. Provisionally and subject to permanent termination until the 60th day after cessation of breach;
- b. Permanently on the 60th day after cessation of breach unless otherwise reasonably notified by the Licensor; or
- c. Permanently if reasonably notified by the Licensor of the violation, this is the first time You have received notice of violation of this License from the Licensor, and You cure the violation prior to 30 days after your receipt of the notice.

Persons subject to permanent termination of rights are not eligible to be a recipient and receive a license under Section 4.8.

9.5 Notwithstanding the above, Licensor reserves the right to release the Database under different license terms or to stop distributing or making available the Database. Releasing the Database under different license terms or stopping the distribution of the Database will not withdraw this License (or any other license that has been, or is required to be, granted under the terms of this License), and this License will continue in full force and effect unless terminated as stated above.

10.0 General

10.1 If any provision of this License is held to be invalid or unenforceable, that must not affect the validity or enforceability of the remainder of the terms and conditions of this License and each remaining provision of this License shall be valid and enforced to the fullest extent permitted by law.

10.2 This License is the entire agreement between the parties with respect to the rights granted here over the Database. It replaces any earlier understandings, agreements or representations with respect to the Database.

10.3 If You are in breach of the terms of this License, You will not be entitled to rely on the terms of this License or to complain of any breach by the Licensor.

10.4 Choice of law. This License takes effect in and will be governed by the laws of the relevant jurisdiction in which the License terms are sought to be enforced. If the standard suite of rights granted under applicable copyright law and Database Rights in the relevant jurisdiction includes additional rights not granted under this License, these additional

rights are granted in this License in order to meet the terms of this License.

Warranty Remedies

Trimble's sole liability and your exclusive remedy under the warranties set forth above shall be, at Trimble's option, to repair or replace any Product that fails to conform to such warranty ("Nonconforming Product"), and/or issue a cash refund up to the purchase price paid by you for any such Nonconforming Product, excluding costs of installation, upon your return of the Nonconforming Product to Trimble in accordance with Trimble's product return procedures than in effect. Such remedy may include reimbursement of the cost of repairs for damage to third-party equipment onto which the Product is installed, if such damage is found to be directly caused by the Product as reasonably determined by Trimble following a root cause analysis.

Warranty Exclusions and Disclaimer

These warranties shall be applied only in the event and to the extent that (a) the Products and Software are properly and correctly installed, configured, interfaced, maintained, stored, and operated in accordance with Trimble's relevant operator's manual and specifications, and; (b) the Products and Software are not modified or misused. The preceding warranties shall not apply to, and Trimble shall not be responsible for defects or performance problems resulting from (i) the combination or utilization of the Product or Software with hardware or software products, information, data, systems, interfaces or devices not made, supplied or specified by Trimble; (ii) the operation of the Product or Software under any specification other than, or in addition to, Trimble's standard specifications for its products; (iii) the unauthorized, installation, modification, or use of the Product or Software; (iv) damage caused by accident, lightning or other electrical discharge, fresh or salt water immersion or spray (outside of Product specifications); or (v) normal wear and tear on consumable parts (e.g., batteries). Trimble does not warrant or guarantee the results obtained through the use of the Product or that software components will operate error free.

THE WARRANTIES ABOVE STATE TRIMBLE'S ENTIRE LIABILITY, AND YOUR EXCLUSIVE REMEDIES, RELATING TO THE PRODUCTS AND SOFTWARE. EXCEPT AS OTHERWISE EXPRESSLY PROVIDED HEREIN, THE PRODUCTS, SOFTWARE, AND ACCOMPANYING DOCUMENTATION AND MATERIALS ARE PROVIDED "AS IS" AND WITHOUT EXPRESS OR IMPLIED WARRANTY OF ANY KIND BY EITHER TRIMBLE NAVIGATION LIMITED OR ANYONE WHO HAS BEEN INVOLVED IN ITS CREATION, PRODUCTION, INSTALLATION, OR DISTRIBUTION INCLUDING, BUT NOT LIMITED TO, THE IMPLIED WARRANTIES OF MERCHANTABILITY AND FITNESS FOR A PARTICULAR PURPOSE, TITLE, AND NON-INFRINGEMENT. THE STATED EXPRESS WARRANTIES ARE IN LIEU OF ALL OBLIGATIONS OR LIABILITIES ON THE PART OF TRIMBLE ARISING OUT OF, OR IN CONNECTION WITH, ANY PRODUCTS OR SOFTWARE. BECAUSE SOME STATES AND JURISDICTIONS DO NOT ALLOW LIMITATIONS ON DURATION OR THE EXCLUSION OF AN IMPLIED WARRANTY, THE ABOVE LIMITATION MAY NOT APPLY OR FULLY APPLY TO YOU.

NOTICE REGARDING PRODUCTS EQUIPPED WITH TECHNOLOGY CAPABLE OF TRACKING SATELLITE SIGNALS FROM SATELLITE BASED AUGMENTATION SYSTEMS (SBAS) (WAAS/EGNOS, AND MSAS), OMNISTAR, GPS, MODERNIZED GPS OR GLONASS SATELLITES, OR FROM IALA BEACON SOURCES: TRIMBLE IS NOT RESPONSIBLE FOR THE OPERATION OR FAILURE OF OPERATION OF ANY SATELLITE BASED POSITIONING SYSTEM OR THE AVAILABILITY OF ANY SATELLITE BASED POSITIONING SIGNALS.

Limitation or Liability

TRIMBLE'S ENTIRE LIABILITY UNDER ANY PROVISION HEREIN SHALL BE LIMITED TO THE AMOUNT PAID BY YOU FOR THE PRODUCT OR SOFTWARE LICENSE. TO THE MAXIMUM EXTENT PERMITTED BY APPLICABLE LAW, IN NO EVENT SHALL TRIMBLE OR ITS SUPPLIERS BE LIABLE FOR ANY INDIRECT, SPECIAL, INCIDENTAL OR CONSEQUENTIAL DAMAGES WHATSOEVER UNDER ANY CIRCUMSTANCE OR LEGAL THEORY RELATING IN ANY WAY TO THE PRODUCTS, SOFTWARE AND ACCOMPANYING DOCUMENTATION AND MATERIALS, (INCLUDING, WITHOUT LIMITATION, DAMAGES FOR LOSS OF BUSINESS PROFITS, BUSINESS INTERRUPTION, LOSS OF BUSINESS INFORMATION, OR ANY OTHER PECUNIARY LOSS), REGARDLESS WHETHER TRIMBLE HAS BEEN ADVISED OF THE POSSIBILITY OF ANY SUCH LOSS AND REGARDLESS OF THE COURSE OF DEALING WHICH DEVELOPS OR HAS DEVELOPED BETWEEN YOU AND TRIMBLE. BECAUSE SOME STATES AND JURISDICTIONS DO NOT ALLOW THE EXCLUSION OR LIMITATION OF

LIABILITY FOR CONSEQUENTIAL OR INCIDENTAL DAMAGES, THE ABOVE LIMITATION MAY NOT APPLY OR FULLY APPLY TO YOU. **PLEASE NOTE: THE ABOVE TRIMBLE LIMITED WARRANTY PROVISIONS WILL NOT APPLY TO PRODUCTS PURCHASED IN THOSE JURISDICTIONS (E.G., MEMBER STATES OF THE EUROPEAN ECONOMIC AREA) IN WHICH PRODUCT WARRANTIES ARE THE RESPONSIBILITY OF THE LOCAL DEALER FROM WHOM THE PRODUCTS ARE ACQUIRED. IN SUCH A CASE, PLEASE CONTACT YOUR TRIMBLE DEALER FOR APPLICABLE WARRANTY INFORMATION.**

Official Language

THE OFFICIAL LANGUAGE OF THESE TERMS AND CONDITIONS IS ENGLISH. IN THE EVENT OF A CONFLICT BETWEEN ENGLISH AND OTHER LANGUAGE VERSIONS, THE ENGLISH LANGUAGE SHALL CONTROL.

Registration

To receive information regarding updates and new products, please contact your local dealer or visit the Trimble website at www.trimble.com/register. Upon registration you may select the newsletter, upgrade or new product information you desire.

Notices

This equipment has been tested and found to comply with the limits for a Class A digital device, pursuant to Part 15 of the FCC rules. These limits are designed to provide reasonable protection against harmful interference when the equipment is operated in a commercial environment. This equipment generates, uses, and can radiate radio frequency energy and, if not installed and used in accordance with the instruction manual, may cause harmful interference to radio communications. Operation of this equipment in a residential area is likely to cause harmful interference, in which case the user will be required to correct the interference at his own expense. Properly shielded and grounded cables and connectors must be used in order to meet FCC emission limits. TRIMBLE is not responsible for any radio or television interference caused by using other than recommended cables and connectors or by unauthorized changes or modifications to this equipment. Unauthorized changes or modifications could void the user's authority to operate the equipment. This device complies with Part 15 of the FCC rules. Operation is subject to the following two conditions: (1) this device may not cause harmful interference, and (2) this device must accept any interference received, including interference that may cause undesired operation.

Responsible Party:
Trimble Navigation
935 Stewart Drive
Sunnyvale CA 94085
Telephone: 1-408 481 8000

Canada

This Class A digital apparatus complies with Canadian ICES-003. Cet appareil numérique de la classe A est conforme à la norme NMB-003 du Canada.

This apparatus complies with Canadian RSS-GEN. Cet appareil est conforme à la norme CNR-GEN du Canada.

Europe

This product has been tested and found to comply with the requirements for a Class A device pursuant to European Council Directive 2006/42/EC and 1999/5/EC, thereby satisfying the requirements for CE Marking and sale within the European Economic Area (EEA). Contains a radio module. These requirements are designed to provide reasonable protection against harmful interference when the equipment is operated in a residential or commercial environment.



Australia and New Zealand

This product conforms with the regulatory requirements of the Australian Communications and Media Authority (ACMA) EMC framework, thus satisfying the requirements for C-Tick Marking and sale within Australia and New Zealand.



Waste Electrical and Electronic Equipment (WEEE)

For product recycling instructions and more information, please go to www.trimble.com/ev.shtml.





Recycling in Europe: To recycle Trimble WEEE (Waste Electrical and Electronic Equipment, products that run on electrical power.), Call +31 497 53 24 30, and ask for the "WEEE Associate". Or, mail a request for recycling instructions to:

Trimble Europe BV
c/o Menlo Worldwide Logistics
Meerheide 45
5521 DZ Eersel, NL

Safety Information

Always follow the instructions that accompany a Warning or Caution. The information it provides is intended to minimize the risk of personal injury and/or damage to property. In particular, observe safety instructions that are presented in the following format:

 **WARNING** – This alert warns of a potential hazard which, if not avoided, could result in severe injury or even death.

 **CAUTION** – This alert warns of a potential hazard or unsafe practice which, if not avoided, could result in injury or property damage or irretrievable data loss.

Note – An absence of specific alerts does not mean that there are no safety risks involved.

Warnings

Auto guidance

 **WARNING** – Auto guidance systems cannot avoid items in the field such as obstacles. Make sure you are adequately trained to operate the auto guidance system.

 **WARNING** – Many large and sudden changes in satellite geometry caused by blocked satellites can cause significant position shifts. If operating under these conditions, auto-guidance systems can react abruptly. To avoid possible personal injury or damage to property under these conditions, disable the auto-guidance system and take manual control of the vehicle until conditions have cleared.

Calibration

 **WARNING** – Incorrect adjustment of *Manual Override Sensitivity* could cause this critical safety feature to fail, resulting in personal injury or damage to the vehicle. Do not to choose a setting that is either too sensitive or not sensitive enough. It is vital to avoid setting the sensitivity so low that the system will not detect any steering wheel motion.

 **WARNING** – During the Deadzone calibration, the system moves the vehicle's steering wheel. To avoid injury, be prepared for sudden vehicle movement.

 **WARNING** – During flow calibration, the machine will become operational. Take all necessary precautions to ensure user safety. Failure to do so may result in serious injury or death.

 **WARNING** – Material will be dispensed during calibration. Make sure that the implement is safe to operate.

Display

 **WARNING** – When the temperature of the display case reaches 65° C (149 ° F) the display shows the following: WARNING! HOT SURFACE, DO NOT TOUCH. The display will dim the screen until the temperature returns to normal. Use caution when touching the display when this warning is visible.

Implement master switch

 **WARNING** – When the implement is down and the master switch is in the On position, the machine is fully operational. Take all necessary precautions to ensure user safety. Failure to do so could result in injury or death.

NH₃, anhydrous ammonia

 **WARNING** – Anhydrous valve and flow calibrations require the vehicle and implement to be moving and the implement must be in the ground (the implement lift switch must be down). Take all necessary precautions to ensure user safety. Failure to do so may result in serious injury or death.

 **WARNING** – NH₃ is an irritant and corrosive to the skin, eyes, respiratory tract and mucous membranes, and is dangerous if not handled properly. It may cause severe burns to the eyes, lungs, and skin. Skin, and respiratory-related diseases could be aggravated by exposure. It is recommended that protective gloves, boots, slicker and/or pants and jacket, and chemical-splash goggles that are impervious to anhydrous ammonia are worn at all times. See [Working with anhydrous ammonia](#).

Cautions

Calibration

 **CAUTION** – Obstacles in the field can cause collisions, which may injure you and damage the vehicle. If an obstacle in the field makes it unsafe to continue the Automated Deadzone calibration, stop the vehicle and turn the steering wheel to disengage the system.

- 1) Wait until the Precision-IQ field application prompts you that the phase is ready to begin.
- 2) Look at the screen to determine whether the next phase will require a left or right turn.
- 3) Reposition the vehicle so that the turn will use the space that you have available.
- 4) Tap the button to begin the next phase.

Safety Information

-
-  **CAUTION** – The wheels can move abruptly during the Steering Proportional Gain procedure while the Autopilot system tests the hydraulic response to its steering commands. To avoid injury, be prepared for vehicle movement.
-

Display

-
-  **CAUTION** – If you leave the display powered on after shutting off the vehicle's ignition, the display power can drain the battery.
-

-  **CAUTION** – Do not press on the screen with a sharp item, such as a pencil. You may damage the surface of the screen.
-

-  **CAUTION** – Do not apply glass cleaner directly to the touchscreen.
-

GNSS interference

-
-  **CAUTION** – The GNSS antenna may experience interference if you operate the vehicle within 100 m (300 ft) of any power line, radar dish, or cell phone tower.
-

Vehicle setup

-
-  **CAUTION** – If you select a *Vehicle Profile* that is not suitable for your vehicle, you may experience degraded system performance.
-

-  **CAUTION** – If you delete a vehicle, all information about the vehicle will be erased.
-

USB drive

-
-  **CAUTION** – Do not remove the USB drive while the display is writing to or from the drive. This will corrupt the data.
-

-  **CAUTION** – Do not use a USB drive in each USB socket at the same time. If you are attempting to upgrade firmware using a USB drive and another USB drive is already in one of the sockets, the firmware upgrade will fail.
-

Working with anhydrous ammonia

Servicing the Equipment

1. Remove the system from operation before performing any maintenance.
2. Thoroughly bleed all system lines and disconnect the nurse tank hose. See [Discharging the System \(page 13\)](#).
3. Make sure that the gauge pressure is at zero before you open the system.
4. Use extreme caution when opening a previously pressurized system.

Discharging the System

1. Turn off the console or vehicle master switch.
2. Completely close the main shut-off valve on the supply or nurse tank.
3. Resume field application until the pressure gauge shows zero pressure.
4. Check again that the console and/or vehicle master switch, and all section switches, are turned off.
5. Completely close the emergency shut-off valve the cooling tower.
6. Bleed and disconnect the nurse tank supply hose from the system.
7. Turn on the console master switch and all section switches.
8. Stand up-wind from the implement and then slowly open the bleed valve(s) until fully open.
9. Allow at least one (1) hour for the system to fully discharge.
10. Before you open the system, make sure that the pressure gauge on the manifold reads zero and that the cooling tower is not cold to the touch. This ensures that all liquid NH₃ has evaporated and that the pressure is discharged.

Note – Frost on any component is a positive indication of trapped NH₃ at low pressure. Lack of frost does not always indicate a lack of NH₃.

Contents

Safety Information	10
Warnings	10
Cautions	11
Working with anhydrous ammonia	13
Servicing the Equipment	13
Discharging the System	13
1 Introduction	23
Precision-IQ field application for the TMX-2050 display	24
Compatibility	24
Changes to this document	25
About this guide	26
Availability of optional features	26
Additional Trimble resources	26
Technical assistance	26
2 Precision-IQ application basics	27
Display power on/off	28
Automatic power on	28
Manual power on	28
Automatic power off	28
Manual power off	29
On-screen user guide	30
Help from the web	30
Touch screen basics	31
Interactive controls	31
Cleaning the touch screen	33
Common controls	34
Lists	34
On / Off buttons	35
Adjusters	36
Setup panels	37
On-screen keyboard	38
On-screen number pad	38
Main views	39
Launcher screen	39
Home screen	39
Run screen	40
Field Manager	40
Prescription Manager	41
App Central	41
Data Transfer screen	41

Contents

Connected Farm Dashboard	42
Status bar	43
System bar	44
Navigation buttons	44
Emergency button	44
Screenshot	44
Menu bar	45
GNSS notification button	46
Main menu	46
Launcher screen	47
Interruption of services	47
Application menu button	47
Home screen	48
Field management buttons - left side	49
Setup buttons - right side	50
Run screen	51
Major function buttons	52
Field operation buttons - left side	53
Feature operation buttons - right side	55
Field Manager	56
Access Field Manager	57
Prescriptions Manager	61
Connected Farm Dashboard	62
Data transfer	63
USB data transfer	64
Office Sync data transfer	65
USB VDB transfer	66
Transfer to Precision-IQ application	66
Transfer data from Precision-IQ application to CFX-750 display or FmX integrated display	67
Transfer data from Precision-IQ field application to Farm Works	67
From Precision-IQ application to Precision-IQ application	69
Upgrade or apply a license for new feature	70
USB port	71
Insert a USB drive	71
Remove USB drive	71
3 Settings	73
About settings	74
About tablet settings	74
Accessibility settings	74
Add account settings	74
Apps settings	75
Backup & reset settings	75

Data usage	75
Display settings	75
Display Units settings	75
ISOBUS settings	76
Language & input settings	76
Location	77
Mapping settings	77
Modem services settings	78
Modem settings	78
Network settings	78
Office Sync settings	79
Patterns settings	80
Curve Features	80
Headlands	80
Boundaries	81
Printing settings	81
Safety and Alarms settings	81
Security	81
Sounds	82
Steering and guidance settings	83
Storage settings	83
Users settings	84
Users and passwords	85
Add a user	85
Take a photo of a user	85
4 Connectivity	87
GNSS receiver settings	88
SBAS corrections	90
RangePoint RTX corrections	91
OmniSTAR G2/HP/GR corrections setup	93
CenterPoint RTX setup	95
CenterPoint VRS corrections	98
RTK corrections	100
CAN message settings	103
Frequency and baud rate	104
DCM-300 modem initial setup	105
Office Sync setup	106
Requirements for Office Sync	106
Connectivity concepts	107
GNSS and drift	107
xFill technology	107
VRS	111

5 Vehicles	113
Vehicle setup	114
Overview of setup	114
Add a vehicle	115
Delete a vehicle	116
Edit a vehicle	117
Save a vehicle	117
Save a complete vehicle profile	118
Save an incomplete vehicle profile	118
Vehicle summary	118
Select a vehicle	119
Manual guidance setup	120
Autopilot system setup	121
Guidance system settings for Autopilot system	121
Controller settings for Autopilot system	122
Sensor settings for Autopilot system	123
Vehicle measurements for Autopilot system	124
OnSwath	126
Autopilot system calibration	127
Calibration for non-tracked vehicles	127
Manual override sensitivity calibration	129
Steering sensor calibration	131
Automated steering deadzone calibration	133
Proportional steering gain	137
Roll correction calibration	139
Line acquisition	143
Engage aggressiveness	144
EZ-Pilot system setup	145
Guidance selection for the EZ-Pilot system	145
Controller settings for EZ-Pilot system	145
Steering speed settings for EZ-Pilot system	146
Vehicle measurements for EZ-Pilot system	148
EZ-Pilot system calibrations	149
Roll correction for EZ-Pilot system	149
Angle per turn calibration for EZ-Pilot system	149
Online aggressiveness calibration for EZ-Pilot system	150
Line acquisition calibration for EZ-Pilot system	150
EZ-Steer system setup	152
Guidance selection for EZ-Steer system	152
Controller settings for EZ-Steer system	153
Steering and speed settings for EZ-Steer system	153
Vehicle measurements for EZ-Steer system	154
EZ-Steer system calibrations	155
Roll correction for EZ-Steer system	155

Angle per turn calibration for EZ-Steer system	155
6 Fields	157
Field Basics	158
Boundaries	158
Guidance lines and patterns	158
Landmarks	159
Tasks, activities and coverage	159
Add a field	160
Select a field	161
Select a field through the map	161
Select a field from the list	161
Enter a field (Run screen)	162
Choose a field to enter	162
Edit a field (Field Manager)	163
7 Implements	167
Implement setup	168
Add an ISOBUS implement	169
Equipment setup	172
Add a serial variable rate implement	173
Add a custom-setup implement	177
Enter implement measurements	180
Pull-type implements	180
Self-propelled equipment	181
Review implement summary	182
Save an implement	182
Select an implement	182
Edit an implement	183
Delete an implement	183
Add a control channel	184
Modify a control channel	185
Remove a control channel	186
Prescriptions	187
Importing prescriptions	187
Exporting prescriptions	188
8 Materials	189
Material list	190
Anhydrous	190
Granular fertilizer	190
Liquid	190
Granular seed	190
Row crop seed	191

Contents

Add a material	192
Edit a material	194
Delete a material	194
9 Operations	195
Preparing for operation	196
Choose a field to enter	196
Fields and guidance	197
Tasks	198
Layers	198
Adjustments during operation	198
Automatic transfer of data	199
Tasks	200
Data stored in each task	200
Create a task	201
Add a task (Run screen)	201
Review existing tasks (Field Manager)	201
Review existing tasks (Field Manager)	201
Edit a task (Field Manager)	202
Coverage logging	203
Manual coverage logging	203
Automatic logging with engage	203
Editing layers	203
Vehicle operation	204
Vehicle position	204
Auto guidance status	205
Steering adjustments	206
Guidance patterns	207
Guidance creation buttons	208
Boundary creation (Run screen)	210
Boundary editing (Field Manager)	211
Boundary activation/deactivation (Field Manager)	212
AB guidance line creation (Run screen)	213
A+ guidance line creation (Run screen)	214
Curved line creation (Run screen)	215
Headland and infill pattern creation (Run screen)	216
Infill pattern shift	218
Change the infill pattern	220
Pivot pattern creation (Run screen)	223
Guidance pattern editing (Field Manager)	224
Pattern activation/deactivation (Field Manager)	225
Guidance adjustments	226
Guidance pattern shifting (Field Manager)	227
Landmarks	228

Landmark buttons	228
Landmark point creation (Run screen)	229
Landmark line creation (Run screen)	229
Landmark area creation (Run screen)	230
Landmark editing (Field Manager)	231
Layers	232
View coverage layers	232
Edit a coverage layer	234
Rate control	235
Section control for ISOBUS or serial rate	236
Section control operation	237
Universal Terminal operation	239
In the Precision-IQ field application	239
Delete previous data	240
Prescriptions	241
Assign a prescription	241
Use a prescription	242
On-screen widgets	244
Access widgets	244
Minimize/maximize, resize	244
Move a widget	244
Remove a widget	245
Area status	245
Position status	246
Speed status	247
Alerts and warnings	248
End of row warning	248
Tight turn warning	248
10 Diagnostics / troubleshooting	249
Diagnostics	250
Precision-IQ field application	251
The display does not turn on.	251
The display is not responsive.	251
The map is not visible on the Home screen.	251
Autopilot system diagnostics	252
Steering performance for Autopilot system	252
Sensor performance for Autopilot system	254
NMEA messages	254
DCM-300 modem status	256
EZ-Pilot system diagnostics	257
Steering performance for EZ-Pilot system	257
Sensor performance for EZ-Pilot system	259
DCM-300 modem diagnostics	260

Contents

Network Status	260
Device Info	260
Cellular	260
Wi-Fi Network	261
EZ-Steer system diagnostics	262
Steering performance for EZ-Steer system	262
Messages and fault codes	263
GNSS and xFill technology status	266
xFill technology status	266
GNSS diagnostics	268
Solution Information	268
Skyplot	268
Troubleshooting	269
Poor accuracy (multipath)	270
Intermittent loss of lock on satellite	270
Loss of initialization	270
Not tracking RTK corrections	271
Poor signal / not receiving a clear signal	271
The receiver is not tracking any satellites.	272
ISOBUS diagnostics	273
Device tab	273
Recording and saving CAN logs	273
Office Sync Diagnostics	274
System diagnostics	275
System performance	275
TM-200 Module diagnostics	276
LED 1	276
LED 2	276
LED 3	276
LED 3 and 4 combination	276
LED 4	276
11 Glossary	279
A	280
B	280
C	281
D	282
E	282
F	282
G	283
H	283
I	283
L	284
M	284

Contents

N	285
P	285
R	285
S	286
T	287
U	287
V	287
W	287

Introduction

In this chapter:

Precision-IQ field application for the TMX-2050 display	24
Changes to this document	25
About this guide	26

The Trimble® Precision-IQ™ application available on the in-cab TMX-2050 display touch screen provides affordable guidance, steering and precision agriculture functionality.

Precision-IQ field application for the TMX-2050 display

The Precision IQ™ field application for the TMX-2050 display is an easy-to-use advanced field management system. The display consists of a 30 cm (12") touch-sensitive, color LCD screen.

Compatibility

Precision-IQ application is compatible with the following automated guidance and steering:

- [Trimble Autopilot™ automated steering system](#)
- [Trimble EZ-Steer® assisted steering system](#)
- [Trimble EZ-Pilot® steering system](#)

Precision-IQ application can use an array of additional products to maximize efficiency, including:

- Creating fields and guidance patterns
- Using guidance patterns for automatic guidance systems
- Logging coverage data
- Output of information for analysis in office-based software (for example Farm Works Software® solutions)

Changes to this document

The changes to Version 4.0, Revision A are:

- Process for upgrading firmware and applying licenses purchased for new features. See [Upgrade or apply a license for new feature \(page 70\)](#).
- Addition of a [Menu bar \(page 45\)](#).
- Changes to the access locations of various [Settings \(page 73\)](#).
- The [Main menu \(page 46\)](#) button has moved to the [Menu bar \(page 45\)](#).
- The label for Virtual Terminal has changed to Universal Terminal.

About this guide

This manual describes how to install, configure, troubleshoot and use the Precision-IQ field application for the TMX-2050 display.

Availability of optional features

All available functions are covered in this manual, however, you may not see all of them on your screen. The Precision-IQ field application includes many optional features. Only the features you have purchased and unlocked will be available to you. See [Upgrade or apply a license for new feature \(page 70\)](#).

Additional Trimble resources

Sources of related information include the following:

- **Product manuals and other publications:** Access various publications (including product manuals, release notes and quick reference guides) about Trimble products at http://www.trimble.com/Support/Support_AZ.aspx.
- **Trimble training courses** - Consider a training course to help you use the Precision-IQ field application to its fullest potential. For more information, visit http://www.trimble.com/Support/Index_Training.aspx.

Technical assistance

If you cannot find the information you need in the product documentation, contact your local reseller.

Alternatively:

1. Visit http://www.trimble.com/support/index_support.aspx.
2. Select the type of support applicable to you.

If you need to contact Trimble technical support:

1. Visit <http://www.trimble.com/global-services/support.aspx>.
2. Click Request Technical Support and login to complete a support request.

Precision-IQ application basics

In this chapter:

Display power on/off	28
On-screen user guide	30
Touch screen basics	31
Common controls	34
Main views	39
Status bar	43
System bar	44
Menu bar	45
GNSS notification button	46
Main menu	46
Launcher screen	47
Home screen	48
Run screen	51
Field Manager	56
Prescriptions Manager	61
Connected Farm Dashboard	62
Data transfer	63
Upgrade or apply a license for new feature ..	70
USB port	71

The Precision-IQ field application for the TMX-2050 display is an application that responds to common touch screen interactions. The various screens used for your work and firmware upgrades and licenses are covered in this chapter.

Display power on/off

Automatic power on

If the display is connected to the ignition source, power on the vehicle. The TM-200 Module sends power to the display when the vehicle powers on.

The display powers on. After a short pause, the [Launcher screen \(page 47\)](#) opens.

To open the Precision-IQ field application, tap .

Note – After you have initially powered on the display, the Precision-IQ field application may not open until the TM-200 Module has initialized or finished booting.

Manual power on

To turn on the display manually, hold the power button down briefly (about half a second). The power button is on the rear of the display.

The display powers on. After a short pause, the [Launcher screen \(page 47\)](#) opens.

To open the Precision-IQ field application, tap .

Note – After you have initially powered on the display, the Precision-IQ field application may not open until the TM-200 Module has initialized or finished booting.

Automatic power off

If the display is connected to the ignition source, when you switch the ignition off, a shutdown/reboot dialog displays. If you do nothing the display shuts off in 60 seconds. If you choose not to shutdown the display, it will remain powered on indefinitely.



CAUTION – If you leave the display powered on after shutting off the vehicle's ignition, the display power can drain the battery.

Manual power off

To manually turn the power off, hold the power down button for one to two seconds. See the following steps.

1. Turn off the display manually by holding the power button down for about two seconds.
2. Choose one of the following options:
 - Shutdown: Powers down the display
 - Reboot: Restarts the display
 - Cancel: Cancels the power off process

Note – Sometimes after you press the power button and tap **Shutdown**, the display does not immediately turn off. This is because the Precision-IQ field application is saving settings. The display will power off after all settings are saved.

If these steps do not cause the power to go off, you can force a shut down of the display by holding the power button for five seconds.

On-screen user guide

Option 1: At the [Menu bar \(page 45\)](#), tap . Then tap **User Guide**.

Option 2: Navigate to the [Launcher screen \(page 47\)](#) and tap .

Note – *If your system is engaged with an automatic steering system and you navigate to the Launcher screen to access the user guide, the steering system will disengage.*

Help from the web

To obtain the User Guide from the web, go to http://www.trimble.com/Support/Support_AZ.aspx.



Touch screen basics



If you are unfamiliar with using a touch screen, this section contains the basics of using a touch screen and how to clean it.

Interactive controls

Use your fingers to interact with buttons, maps, lists and selectors.

 **CAUTION** – Do not press on the screen with a sharp item, such as a pencil. You may damage the surface of the screen.

Item	Action	Explanation
Buttons and selectors	Tapping 	<p><i>Tap</i> means to touch a point on the screen and then remove your finger from the screen. A <i>tap</i> is a single touch. You do not move your finger while touching the screen. You tap buttons, items in lists, points on a range, and so on.</p>
Lists	Scrolling 	<p>When a list has more items than fit on a screen or in a box, you can move the list to see all items by scrolling up or down. To scroll:</p> <ol style="list-style-type: none"> 1. Touch anywhere in the list and hold your finger on the screen. 2. Move your finger in the direction that you want to move the list - left, right, up or down. 3. Remove your finger when you are satisfied with the position of the list. <p>For examples of lists, see Lists (page 34).</p>
Home screen Run screen Field Manager	Zooming in and out 	<p>You can enlarge the view to see more detail (zoom in) or reduce the view to see less detail but more area (zoom out). To zoom in:</p> <ol style="list-style-type: none"> 1. Touch the screen where you want to see more detail with your thumb and a finger close together (or you can use two fingertips).

Item	Action	Explanation
		<ol style="list-style-type: none"> 2. Move your fingers apart while still touching the screen. 3. Remove your fingers from the screen when you are satisfied with the zoom level. <p>To zoom out:</p> <ol style="list-style-type: none"> 1. Touch the screen where you want to reduce the level of detail with your thumb and a finger an inch or more apart (or you can use two fingertips) 2. Move your fingers together while still touching the screen. 3. Remove your fingers from the screen when you are satisfied with the zoom level.
On the Home screen	Panning 	<p>Panning in a map on the Run screen moves the map left or right.</p> <p>Panning means you can shift the view to show information that is not in view on the screen.</p> <ol style="list-style-type: none"> 1. Touch anywhere on the screen with your finger and hold it on the screen. 2. Move your finger in the direction that you want to move the map. 3. Remove your finger when you are satisfied with the position of the map.
Settings shortcut	Swiping down 	<p>Swipe down on the upper right area of the screen to quickly access the brightness control and Display settings.</p> <p>See Display settings (page 75).</p>

Cleaning the touch screen



CAUTION – Do not press on the screen with a sharp item, such as a pencil. You may damage the surface of the screen.

Use the following supplies to clean the touch screen of the display:

- Ammonia-free glass cleaner
- Soft, lint-free cotton cloth
- 50% isopropyl alcohol



CAUTION – Do not apply glass cleaner directly to the touchscreen.

1. Apply a small amount of ammonia-free glass cleaner to the cloth.
2. Gently rub the touchscreen with the cloth.
3. To remove stains or smudges, use a cotton cloth dampened with 50% isopropyl alcohol.



Tip – Clean the touch screen while it is powered down. It is easier to see dirt and fingerprints when the touch screen is dark.

Common controls

Common controls provide a way for you to:

- Complete settings and configuration with [Setup panels \(page 37\)](#)
- Enter information using an [On-screen keyboard \(page 38\)](#) and [On-screen number pad \(page 38\)](#)
- Work with [Lists \(page 34\)](#)
- Turn an option on or off with [On / Off buttons \(page 35\)](#)
- Choose values within a range using [Adjusters \(page 36\)](#)

Lists

Lists vary depending on their function.

Menu lists

Menu lists contain a list of items that lead to additional information or areas.

- Tap a list item to reveal additional information or choices to the right of the menu.
- Some lists have expand/collapse capabilities. Tap the up or down arrow to expand and collapse sections.

Tap a list item to reveal additional information or choices to the right of the menu.

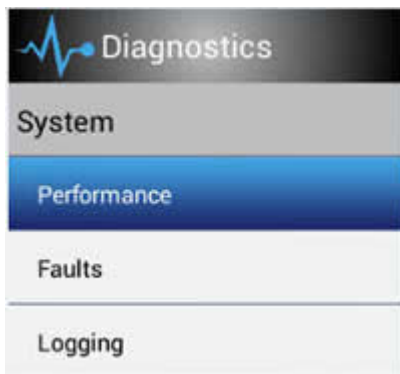

Some lists have expand/collapse capabilities. Tap the up or down arrow to expand and collapse sections.



Selection lists

Some lists contain items for you to select. If the list is longer than what is in your view, a scroll bar displays to the right of list items. You can use this to scroll up and down the list. After you tap your selection on the list, the list closes.



On / Off buttons

On/off buttons enable you to turn items on and off.

The red X indicates this item is turned off. Tap to turn the item on.



The green check mark indicates this item is turned on. Tap to turn the item off.



Adjusters

With adjusters, you can select a value from an available range.

Example: Slider bars

The pointer (rectangular button on the slider bar) indicates the value.



To use the slider bar, you can:

- Change the value by increments - Tap on the plus/minus signs at each end of the slider bar, in the direction that you want to move the pointer.
- Move to a value:
 - a. Touch the pointer on the slider bar.
 - b. Move the pointer toward the minus or plus sign.
 - c. Remove your finger when you are satisfied with the position of the pointer.
- Enter an exact number - If the screen also has a button showing the value, tap it. Then use the on-screen number pad to enter the number.

Example: Increase/decrease adjusters

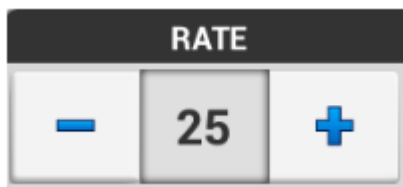

Adjusters with plus and minus buttons enable you to increase or decrease the number by tapping the plus/minus buttons. You can also tap on the number and enter the number using the on-screen keyboard/number pad.



Setup panels





Panels display so that you can setup or configure items. Panels include a set of controls specifically for that setup or configuration.



Button	Explanation
Next	Tap to go to the next section. (Displayed within the setup panel.)
Back	Tap to go to the previous section. (Displayed within the settings panel.)
	Within specific setup panels, tap to save the settings you currently entered.
	Tap (located on the bottom System bar (page 44)) to go to the <i>Home</i> screen and exit the setup process without saving any currently entered settings.





On-screen keyboard

The on-screen keyboard displays when you tap a field for entering information. You can enter text or numbers.

To:	Tap...
Enter number(s)	The number on the on-screen keyboard
Enter letter(s)	The letter on the on-screen keyboard
Delete letters or numbers	
Remove all the letters or numbers you have entered	 and hold down
Cause the keyboard to no longer display	 

On-screen number pad

The on-screen number pad displays when you tap a field for entering a number.

To:	Tap...
Enter a number	The number
Delete number(s)	
Remove all the numbers you have entered	 and hold down
Cause the keyboard to no longer display	 

Main views

The Precision-IQ field application has different screens for your work.

CAUTION – Do not press on the screen with a sharp item, such as a pencil. You may damage the surface of the screen.

Launcher screen

The [Launcher screen \(page 47\)](#) displays the applications available on the TMX-2050 display in the same way any Android application does. When you power on the display or reboot it, the Launcher screen is the first screen to display.

To go to the Launcher screen, tap the Home button  on the [System bar \(page 44\)](#).



Home screen

The [Home screen \(page 48\)](#) is primarily for set up, including:

- Adding fields
- Creating, setting up and calibrating vehicles, implements and materials

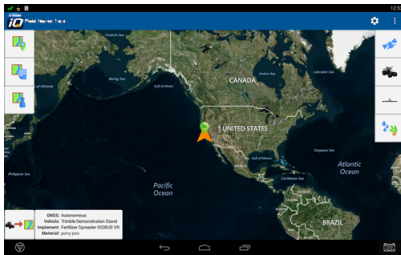

Run screen

At the [Run screen \(page 51\)](#), you:

- Perform field activities
- Create guidance mapping elements (boundaries, guidance patterns, and landmarks)
- Make adjustments to steering guidance, and rate and section control
- Log coverage



Field Manager

At the [Field Manager \(page 56\)](#), you:

- Activate the guidance mapping elements you want to follow
- Edit and refine guidance mapping elements
- Associate fields to clients and farms
- Continue a task or begin a new task



Prescription Manager



Requires Unlock – This feature requires a license unlock to set up and use. See [Upgrade or apply a license for new feature \(page 70\)](#).

At the Prescription Manager, you can:

- [Assign a prescription \(page 241\)](#)
- [Use a prescription \(page 242\)](#)

App Central

App Central contains:

- Additional applications that you may find useful to download, including Connected Farm applications and applications created by other companies
- Functionality for upgrading firmware and applying licenses for new features you have purchased. See [Upgrade or apply a license for new feature \(page 70\)](#).

To access App Central, go to the [Launcher screen \(page 47\)](#) and tap .

Data Transfer screen

At the Data Transfer screen, you can transfer data between Precision-IQ field application and a USB drive. See [USB data transfer \(page 64\)](#). To access the Data Transfer screen, tap  on the [Menu bar \(page 45\)](#).

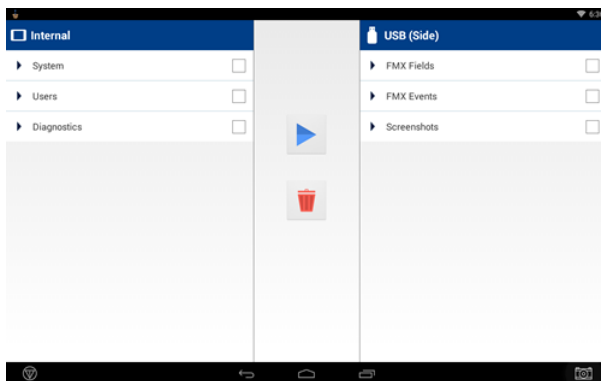

Connected Farm Dashboard

The [Connected Farm Dashboard \(page 62\)](#) allows you access your fields and data with an Internet connection (including wireless). (Requires subscriptions and DCM-300 modem.)



Status bar

On the top left of your screen, a status bar shows status such as GNSS status, upgrade and insertion of a USB drive.



To see more detail, place a finger on the top left of the top display bar and swipe down.

A detailed list displays.

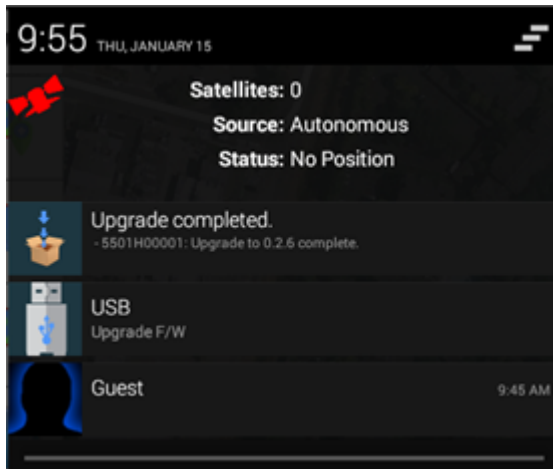

You can tap specific buttons in the notification list to immediately access details on each item.

The top right of the system bar shows the time and indicators for the status of the:

- Signal strength
- Speaker (off or on)
- Bluetooth
- Any other appropriate items, such as airplane mode

Also see [GNSS notification button \(page 46\)](#).

System bar



CAUTION – Do not press on the screen with a sharp item, such as a pencil. You may damage the surface of the screen.



The system bar is always available at the bottom of the screen on the Precision-IQ field application.



Navigation buttons

Navigation buttons in the middle of the bottom system bar enable you to navigate between views.



Button	Tap to...
	Go to the Home screen (page 48) .
	Go to the Launcher screen (page 47) .
	See all views. Tap the view you want to fill the screen.

Emergency button

On the left-hand side of the system bar, the Emergency button is displayed at all times. To cancel all functions controlled by the display, tap . This button is useful if you need to quickly disengage an automatic steering system.



Note – Tapping this button does not turn the vehicle off or stop it. It only cancels display-controlled functions such as automatic steering systems, spraying, seeding and so on.

Screenshot

To capture a screen, tap the camera button  on the far right of the system bar. The display stores your screen shot on the USB drive under Pictures\screenshots. To transfer screenshots to a USB drive, see [USB data transfer \(page 64\)](#).

Menu bar



The menu bar is located below the [Status bar \(page 43\)](#) and contains:

- The name of the selected field, if any
- The current task being performed, if any
- The menu button  to access:
 - [Display Units settings \(page 75\)](#)
 - [Mapping settings \(page 77\)](#)
 - [Patterns settings \(page 80\)](#)
 - [Steering and guidance settings \(page 83\)](#)
 - [Safety and Alarms settings \(page 81\)](#)
 - [ISOBUS settings \(page 76\)](#)
 - [Office Sync settings \(page 79\)](#)
 - [Users and passwords \(page 85\)](#)
 - [About settings \(page 74\)](#)
- The Precision-IQ field application [Main menu \(page 46\)](#) button  to access:
 - [Diagnostics \(page 250\)](#)
 - [On-screen user guide \(page 30\)](#)
 - [Data transfer \(page 63\)](#)
 - **Universal Terminal:** Open the Universal Terminal to set up ISO-certified equipment. This option is not available unless you have turned on Universal Terminal in Settings. See [ISOBUS settings \(page 76\)](#) and [Universal Terminal operation \(page 239\)](#).

GNSS notification button

A GNSS notification button displays on the [Status bar \(page 43\)](#) to indicate the status of your GNSS connection.

Swipe down on the [Status bar \(page 43\)](#) to see the detail menu. Tap the GNSS button on the menu. The system takes you to the Diagnostics screen for any troubleshooting you want to do.

Notification Button	Indicates...
 Green	GNSS connection is normal.
 Yellow	GNSS connection is converging.
 Red	No GNSS connection is available.

Main menu

Tap  on the [Menu bar \(page 45\)](#) to access the main menu for the Precision-IQ field application. A panel of buttons displays that you can tap to access the following areas:

- [Diagnostics \(page 250\)](#): Open the Diagnostics screen.
- [Data transfer \(page 63\)](#): Go to the Data Transfer screen.
- [On-screen user guide \(page 30\)](#): Display the user guide.
- Universal Terminal: Open the Universal Terminal to set up ISO-certified equipment. This option is not available unless you have turned on Universal Terminal in Settings. See [ISOBUS settings \(page 76\)](#) and [Universal Terminal operation \(page 239\)](#).

Launcher screen



Applications you are using or choose to place on the Launcher screen include:

- The Precision-IQ field application
- The FmX® Plus application
- Connected Farm applications
- App Central, where you can download applications and [Upgrade or apply a license for new feature \(page 70\)](#)
- Additional applications downloaded from App Central
- Universal Terminal (tap ).

The Precision-IQ field application and FmX Plus application cannot be open at the same time. If you are switching from Precision-IQ application to the FmX Plus application:

1. Reboot the display by holding down the power button for 1-2 seconds.
2. When the option menu displays, tap **Reboot**.

Interruption of services

If automatic steering, spraying, seeding or other services are engaged in the Precision-IQ field application and you go to the Launcher screen, all automatic systems will disengage.

Application menu button

To see all the application icons on the Launcher screen, tap the application menu button .

Home screen

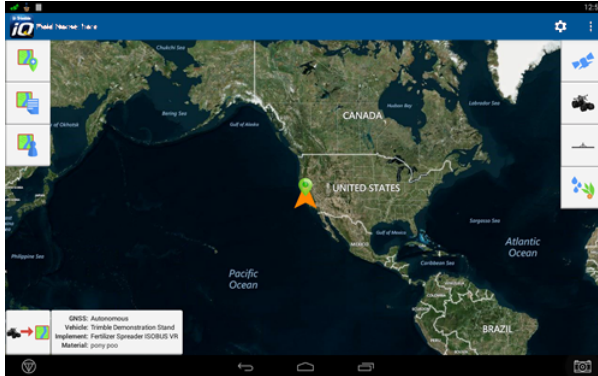

When you open the Precision-IQ field application, the **Home** screen displays, showing a background of one of the following:

- With a functioning DCM-300 modem and a GNSS/GPS fix: A satellite image of the area.
- Without a functioning DCM-300 modem: A blank screen.

At the **Home** screen, you can complete tasks for setup and for managing fields, including:







- Set up and select vehicles, implements and materials
- Set up GNSS
- View the Connected Farm dashboard
- Create fields
- Enter the Field Manager to edit and refine fields and guidance boundaries and patterns
- Enter the **Run** screen to perform field activities

Buttons on the **Home** screen include:

- [Field management buttons - left side \(page 49\)](#) on the left side of the screen
- [Setup buttons - right side \(page 50\)](#) on the right side of the screen





Field management buttons - left side

Buttons on the left side of the **Home** screen are for field management.

Button	Tap to...
Hide 	Hide field operation buttons on the left side of the screen.
Show 	Show field operation buttons on the left side of the screen
Add field 	Add a new field. See Add a field (page 160) .
List fields 	Show a list of existing fields. Tap the name of the field to select it. Tap again to hide the list of fields. See Select a field (page 161) .
Field Manager 	Open Field Manager for the selected field. See Field Manager (page 56) .
Connected Farm 	Open the Connected Farm™ dashboard. (Requires a connected DCM-300 modem.) See Connected Farm Dashboard (page 62) .
Enter Field 	Begin field activities by entering the Run screen. (You must select a vehicle, implement, and field first.) The Run screen displays, where you can perform field activities, including: <ul style="list-style-type: none"> • Engage guidance • Log coverage for current operations • Create boundaries, guidance patterns, landmarks, and so on See Run screen (page 51) .

Setup buttons - right side

Buttons on the right side of the **Home** screen are primarily for setup.

Button	Tap to...
GNSS 	Set up GNSS. See GNSS receiver settings (page 88) .
Vehicle 	Add, edit or select a vehicle, as well as set up and calibrate an assisted guidance system such as the Autopilot, EZ-Pilot, or EZ-Steer system. See Add a vehicle (page 115) .
Implement 	Add, edit or select an implement. See Add an ISOBUS implement (page 169) , Add a serial variable rate implement (page 173) or Add a custom-setup implement (page 177) .
Material 	Add, edit, and select materials. See Add a material (page 192) .

Run screen



CAUTION – Do not press on the screen with a sharp item, such as a pencil. You may damage the surface of the screen.

The **Run** screen enables you to perform field operations such as:

- Creating guidance boundaries and patterns
- Accessing Field Manager to edit and refine guidance boundaries and patterns
- Using auto guidance (with Autopilot system, EZ-Pilot system or EZ-Steer system)

Before you can enter the **Run** screen to perform field activities, you must:

- [Select a vehicle \(page 119\)](#)
- [Select an implement \(page 182\)](#)
- [Select a field \(page 161\)](#)
- Have a GNSS connection. See [GNSS receiver settings \(page 88\)](#).



For more information on selecting a vehicle, field and implement, see [Enter a field \(Run screen\) \(page 162\)](#).

Buttons on the **Run** screen include:

- [Field operation buttons - left side \(page 53\)](#) on the left side of the screen
- [Feature operation buttons - right side \(page 55\)](#) on the right side of the screen
- Widget button : Opens the widget menu to add individual widgets, add all widgets or remove all widgets. See [On-screen widgets \(page 244\)](#).







Major function buttons

These buttons are related to major functions on the **Run** screen.

Button	Explanation
	Section master button. See Section control for ISOBUS or serial rate (page 236) .
	Coverage button. See Coverage logging (page 203) .

Field operation buttons - left side





Buttons for field operation enable you to create guidance and landmark elements, view map layers, show or hide status widgets and access Field Manager.

Button	Tap to...
Hide 	Hide field operation buttons on the left side of the screen.
Show 	Show field operation buttons on the left side of the screen.
Field Manager 	Open Field Manager for the selected field. See Field Manager (page 56) .
Layers 	View various map layers. Layers represent activities that have occurred. For example, a layer can show the coverage completed so far or the speed traveled over an area. See Layers (page 232) .
Guidance Lines and Patterns 	Open the guidance buttons to create: <ul style="list-style-type: none"> • Boundaries See Boundary creation (Run screen) (page 210). • Guidance lines. See: <ul style="list-style-type: none"> • A+ guidance line creation (Run screen) (page 214) • AB guidance line creation (Run screen) (page 213) • Curved line creation (Run screen) (page 215) • Pivot patterns See Pivot pattern creation (Run screen) (page 223) • Headlands See Headland and infill pattern creation (Run screen) (page 216). Also see Pattern activation/deactivation (Field Manager) (page 225) .
Landmarks 	View options to create: <ul style="list-style-type: none"> • Line See Landmark line creation (Run screen) (page 229). • Areas

Button	Tap to...
	<p>See Landmark area creation (Run screen) (page 230)</p> <ul style="list-style-type: none">• Points <p>See Landmark point creation (Run screen) (page 229).</p>
<p>Prescriptions</p> 	<p>Open the Prescriptions Manager.</p> <p>See:</p> <ul style="list-style-type: none">• Prescriptions Manager (page 61)• Use a prescription (page 242)• Assign a prescription (page 241)

Feature operation buttons - right side

Using feature operation buttons, you can make adjustments to various features while performing field activities. With the exception of the **Menu** button, these buttons are specific to applications and depend on which features you are using.

Button	Tap to...
<p>Adjust Steering</p> 	<p>View options:</p> <ul style="list-style-type: none"> • Adjust vehicle aggressiveness • Enable or disable autosteering <p>See Steering adjustments (page 206).</p>
<p>Adjust Guidance</p> 	<p>View options to adjust:</p> <ul style="list-style-type: none"> • Nudge • Re-mark • Implement Draft Correction <p>See Guidance adjustments (page 226).</p>
<p>Adjust Rate Control</p> 	<p>View options to adjust the actual and target rate. See Rate control (page 235).</p>
<p>Engage Auto Guidance</p> 	<p>Engage your auto guidance system. See Vehicle operation (page 204).</p>

Field Manager

At the Field Manager, you edit and refine elements in and associated with each field.

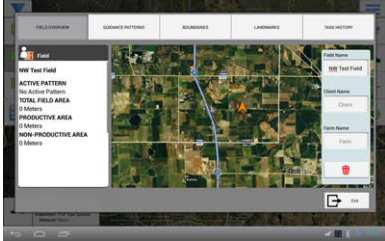



The Field Manager shows information directly associated with the field you have selected and enables you to perform functions listed in the following table.

Note – Add and select a field before entering Field Manager. See [Add a field \(page 160\)](#) and [Select a field \(page 161\)](#).



Section	Functions Available
Field Overview See Field overview buttons (page 57) .	Rename the field, client and farm. See Edit a field (Field Manager) (page 163) .
Guidance Patterns See Guidance pattern buttons (page 57) .	<ul style="list-style-type: none"> • Activate or deactivate lines and patterns. • Shift a line. • Adjust the radius of a pattern. • Resize a shape (other than pivot shape). See Guidance patterns (page 207).
Boundaries See Boundary buttons (page 58) .	<ul style="list-style-type: none"> • Activate or deactivate a boundary. • Resize a boundary. • Rename a boundary. See Boundary editing (Field Manager) (page 211).
Landmarks See Landmark buttons (page 59) .	<ul style="list-style-type: none"> • Edit, delete or rename a landmark. • Change the category that a landmark is assigned to. • See Landmark editing (Field Manager) (page 231).
Task History See Task history buttons (page 60) .	<ul style="list-style-type: none"> • Start a new task. • Rename a task. • See Tasks (page 200).

Access Field Manager



You can access the Field Manager from either the **Home** or **Run** screen.







- At the **Home** screen, select a field. See [Select a field \(page 161\)](#). Tap .
- At the **Run** screen, tap . The Field Manager opens the field you are currently in.

Field overview buttons



Button or Entry Box	Tap to...
<p>Exit</p> 	Exit Field Manager.
	Delete an item
Field name	Edit the field name.
Client name	Enter the name of the client (optional).
Farm name	Enter the name of the farm (optional).





Guidance pattern buttons

Button or Entry Box	Tap to...
<p>Deactivate</p>  <p>(Black)</p>	Deactivate a line. For more information, see Pattern activation/deactivation (Field Manager) (page 225) .
<p>Activate</p>  <p>(Red)</p>	Activate a line. See Pattern activation/deactivation (Field Manager) (page 225) .
Deactivate Shape	Deactivate a pattern (headland, boundary, pivot).



Button or Entry Box	Tap to...
 (Black)	See Pattern activation/deactivation (Field Manager) (page 225) .
Activate Shape  (Red)	Activate a pattern (headland, boundary, pivot). For more information, see Pattern activation/deactivation (Field Manager) (page 225) .
	Adjust the radius of a pivot shape. For more information, see Guidance pattern editing (Field Manager) (page 224) .
	Resize a shape other than a pivot shape. See Guidance pattern editing (Field Manager) (page 224) .
	Shift a line. See Guidance pattern shifting (Field Manager) (page 227) .
	Delete a selected line or pattern.
Name of Pattern	Change the name of the line or pattern.

Boundary buttons

Button or Entry Box	Tap to...
Deactivate Shape  (Black)	Deactivate a pattern (headland, boundary, pivot). See Pattern activation/deactivation (Field Manager) (page 225) .
Activate Shape  (Red)	Activate a pattern (headland, boundary, pivot). See Pattern activation/deactivation (Field Manager) (page 225) .

Button or Entry Box	Tap to...
	Adjust the radius of a pivot shape. For more information, see Guidance pattern editing (Field Manager) (page 224) .
	Resize a shape other than a pivot shape. See Guidance pattern editing (Field Manager) (page 224) .
	Shift a line. See Guidance pattern shifting (Field Manager) (page 227) .
	Delete a selected boundary.
Boundary Name	Change the name of the highlighted boundary.

Landmark buttons

Button or Entry Box	Tap to...
Category 	Assign a category to a landmark point, line or area. For more information, see Pattern activation/deactivation (Field Manager) (page 225) .
Convert 	Convert a selected: <ul style="list-style-type: none"> • Productive area to a non-productive one • Non-productive area to a productive one See Pattern activation/deactivation (Field Manager) (page 225) .
	Delete a selected landmark.
Landmark Name	Change the name of the highlighted landmark.

Task history buttons

Button or Entry Box	Tap to...
Continue Task 	Continue the task you have selected in the list on the right-hand side. See Tasks (page 200) .
Start New Task	Begin a new task.
Task Name	Change the name of the highlighted task.



Prescriptions Manager



Requires Unlock – This feature requires a license unlock to set up and use. See [Upgrade or apply a license for new feature \(page 70\)](#).

At the Prescriptions Manager, you assign a prescription to a channel and determine additional settings related to the prescription. You can access the Prescriptions Manager from the **Run** screen,

tap . The Prescriptions Manager displays.

Item	Tap to...
Enabled Channels list	Select the channel you want to assign a prescription to.
Prescription File Name	Show a list of prescription files associated with the field you have selected.
Column Name	Show the columns that are a part of the prescription file.
Column Units	Show the unit type you will be using for the prescription.
Lead Time	Enter the lead time before the application begins.
When Outside Prescription	Choose what happens when you are outside of the prescription boundary. Close (default), Default Rate or Last Rate.
Finish	Let the system know your entries are complete.
Next	Go to the next settings for prescription assignment.
Back	Go to the previous settings for prescription assignment.
	Save your settings and exit the Prescriptions Manager.
	Remove any edits to the settings and exit the Prescription Manager.

Connected Farm Dashboard

The Connected Farm dashboard enables you to access your fields from a wired connection or wireless Internet connection using a DCM-300 modem.



Feature	Description	Requirements and Restrictions
Rainfall	Check rainfall totals for a location for the past 24 hours without the use of physical rain gauges. Updates every 10 minutes.	Requires subscription to RainWave.
Weather	<ul style="list-style-type: none"> Add a single or multiple locations to view current temperature, wind speed, wind direction, humidity, and chance of precipitation. View the weather forecast for each location. Set up a Doppler radar map to show upcoming weather patterns. 	Doppler radar map available in the United States and Canada only
Commodities	<ul style="list-style-type: none"> Create your own commodity list and rearrange it to your preference. View the previous day's closing price for each commodity. 	US only

Data transfer

You can transfer data:

- Using a USB drive
- Wirelessly with Office Sync
- To another display

Transfer From	Transfer To	See...
Precision-IQ application	FmX integrated display or FmX Plus application	USB data transfer (page 64)
Precision-IQ application	CFX-750™ display	USB data transfer (page 64)
FmX® integrated display or FmX Plus application	Precision-IQ application	Transfer to Precision-IQ application (page 66)
CFX-750 display	Precision-IQ application	Transfer to Precision-IQ application (page 66)
Precision-IQ application	Farm Works™	Transfer data from Precision-IQ field application to Farm Works (page 67)
Precision-IQ application	Precision-IQ application	From Precision-IQ application to Precision-IQ application (page 69)



USB data transfer

The following steps explain how to transfer your data from the Precision-IQ field application to a USB drive or from a USB drive to the Precision-IQ field application.

Note – Make sure your USB drive has the AgGPS folder on the root directory.



CAUTION – Do not remove the USB drive while the display is writing to or from the drive. This will corrupt the data.

1. Make sure you have the Precision-IQ field application open.
2. Insert the USB drive into one of the USB ports on the display. See [USB port \(page 71\)](#).
3. Tap  on the [Menu bar \(page 45\)](#).
4. Tap **Data Transfer**. The Data Transfer screen displays.
5. To expand an item on either list, tap a category name.
6. To select all files in a category, tap the box beside the category name. A check mark displays.
7. To deselect all files in a category, tap the box beside the name.
8. To select an individual file, tap the box beside the file name.
9. Tap  to move the item to the USB drive.
10. To delete an item, tap the box next to the item in either list and tap .

Note – You cannot delete an item that is actively selected or currently being transferred.

Office Sync data transfer

With a DCM-300 modem, and a subscription to Office Sync, information can wirelessly transfer from the display to the office or Connected Farm, including wireless upgrades. This requires:

- A Connected Farm account
- Unlock for Office Sync
- DCM-300 modem
- A data plan or access to Wi-Fi

The type of data you can transfer from your vehicle to the office, includes:

- Planned and completed jobs
- A/B guidance lines
- Prescription maps
- Drainage designs
- Soil sampling and scouting maps
- Variable rate prescription maps
- Application maps
- Yield maps

As part of Office Sync setup, you decide:

- How often you want the display to check the server for data transfer
- How often data is sent from the display to the office
- Whether to send the data automatically or after you have confirmed to send data

When Office Sync is transferring data,  displays in the [Status bar \(page 43\)](#).

See also:

- [Office Sync setup \(page 106\)](#)
- [Requirements for Office Sync \(page 106\)](#)
- [Modem services settings \(page 78\)](#)
- [Office Sync Diagnostics \(page 274\)](#)

USB VDB transfer



When you transfer data, saved vehicles do not include the vehicle configuration file (.vdb) for Autopilot. To transfer this configuration data:

1. Connect a laptop that has the Autopilot Toolbox software to the serial port of the NavController that contains the vehicle config file you want.
2. Using Autopilot Toolbox, save the config (.cfg) file to the laptop.
3. Transfer the saved config file from the laptop to a USB drive in the folder AgData/Profiles.
4. Make sure you have the Precision-IQ field application open.
5. Insert the USB drive containing the config file in the USB socket of the TMX-2050 display.

Transfer to Precision-IQ application

To move files from the CFX-750™ display, FmX integrated display or FmX Plus application to the Precision-IQ field application, follow the steps below.

Note – Make sure your USB drive has the AgGPS folder on the root.

1. Insert the USB drive into the CFX-750 display, FmX integrated display or TMX-2050 display.
If files were created on the CFX-750 display, change the file extension from .CFG to .cfg before transferring them to the Precision-IQ field application.
2. Transfer the files from the display to the USB drive.
3. Remove the USB drive from the CFX-750 display, FmX integrated display or TMX-2050 display.
4. Make sure you have the Precision-IQ field application open.
5. Insert the USB drive into one of the USB sockets on the TMX-2050 display.
6. Tap  on the [Menu bar \(page 45\)](#) and select Data Transfer. The Data Transfer screen displays.
Note – Whether you are transferring data from the CFX-750 display, FmX integrated display or FmX Plus application, the item in the USB list will show the data as FmX integrated display data.
7. Tap an item to expand it on the USB list.
8. Tap the item(s) you want to transfer.
9. Tap  to move the item(s) to the internal list.
10. To delete an item, tap the item in either list and tap .

Transfer data from Precision-IQ application to CFX-750 display or FmX integrated display

To transfer from Precision-IQ field application to the CFX-750™ display, FmX integrated display or FmX Plus application using a USB drive, the same steps for [USB data transfer \(page 64\)](#) apply, except: All data transferred from the Precision-IQ field application must be "decoded" by Farm Works software before it can be used by these legacy displays. See [Transfer data from Precision-IQ field application to Farm Works \(page 67\)](#).

1. Transfer data from Precision-IQ field application to a USB drive. See [USB data transfer \(page 64\)](#).
2. Insert the USB drive into your computer and transfer the data into Farm Works.
3. After Farm Works has received the data, you can now copy the data to a USB drive and then transfer it to CFX-750™ display, FmX integrated display or FmX Plus application.

Note – Make sure your USB drive has the AgGPS folder on the root.

Transfer data from Precision-IQ field application to Farm Works

To transfer files from the Precision-IQ field application to Farm Works, follow the steps below.

Note – Make sure your USB drive has the AgGPS folder on the root.

1. Transfer the files from Precision-IQ field application to a USB drive.
2. Insert the USB drive into your computer and open Farm Works. If you have transferred the data using Office Sync, open Farm Works.
3. Open the **Read Job Data** dialog by clicking either of these:

-  (Read Job Data icon)
- File menu and select **Read Job Data** from the menu

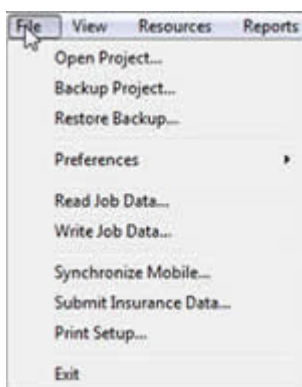

The system displays the **Read Job Data** window.

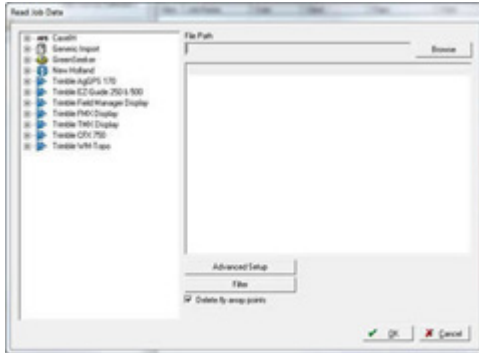

4. In the left column of the **Read Job Data** window, click + next to **Trimble TMX Display**.
5. Under **Trimble TMX Display**, select where the data is stored that you want to transfer.
 - For data transferred into Farm Works using a USB drive, select **All Data - Memory Drive**.



- For data transferred into Farm Works using Office Sync, select **All Data - Folder**.
6. Under **File Path**, click **Browse** to find the drive or folder where the data is located. After this is complete, your data will be listed in the right-hand column.

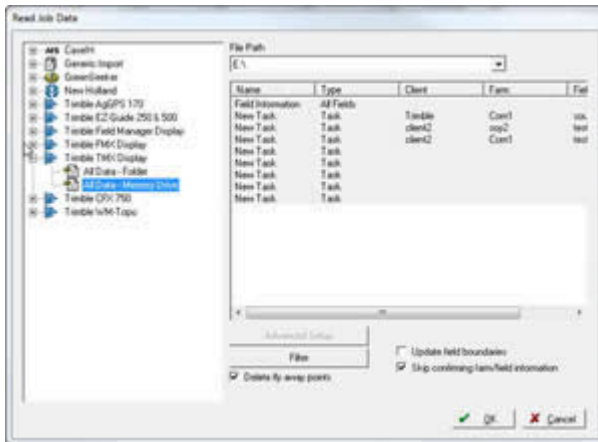

Note – If you wish to filter the files before transfer, see the online help for Farm Works for filtering instructions

7. In the left-hand column, select the job(s) to import.
8. Click **OK**. The import progress shows as files are importing. After import is complete, the system **Linker** window displays.

The left-hand column titled **Operation Resources** shows the files created on the Precision-IQ field application. The right-hand column titled **Desktop Resources** shows files currently in Farm Works.

9. Select an item from the **Operation Resources** list.

- a. If there is no counterpart to the item you selected in the **Desktop Resources** list, click the checkbox **Show Retired**. The system displays any additional files that were marked as **Retired**. If there is still no counterpart to this item in the **Desktop Resources** list, click



. The system creates a new container on the desktop for the item and links it.

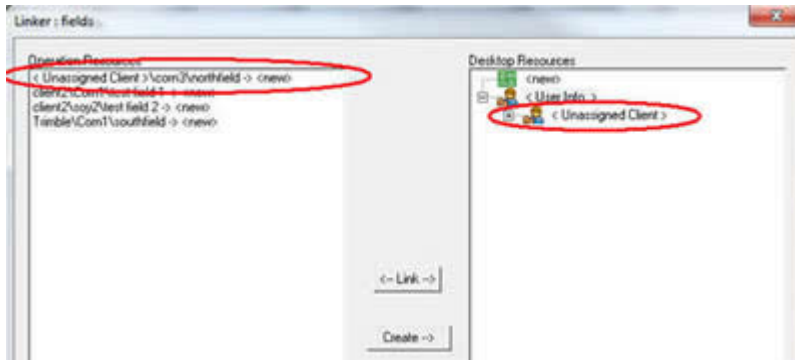

- b. If there is a counterpart to this item in the **Desktop Resources** list, highlight the item and click . The information is now moved to that location on the desktop.

10. After all items have been linked or created, click **OK**. All files are stored in Farm Works at the correct location.

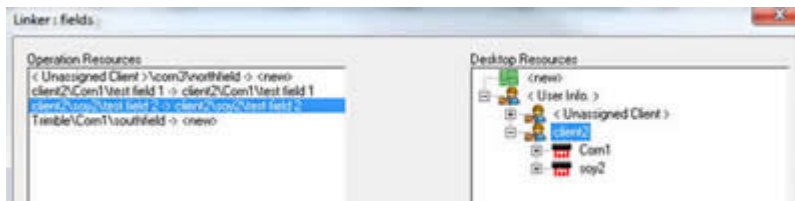









From Precision-IQ application to Precision-IQ application

From Precision-IQ field application to the office or another Precision-IQ field application:

- Using a USB drive: To transfer data through a USB drive, see [USB data transfer \(page 64\)](#).
- Wireless (Office Sync):
 - Ensure you meet the requirements for transferring using Office Sync. See [Office Sync data transfer \(page 65\)](#) in this section.
 - Set up Office Sync. See [Modem services settings \(page 78\)](#).

Upgrade or apply a license for new feature

To apply a license you have purchased for an upgrade or to unlock a new feature:

1. If the display is not on, power on the display.
 2. Insert a USB drive into a USB port of the TMX-2050 display. See [USB port \(page 71\)](#).
 3. At the [Launcher screen \(page 47\)](#), tap  to open App Central.
 4. Tap  to open the menu.
 5. Tap **License**. The *License* screen displays, showing any licenses you have already applied.
 6. Tap .
 7. To scan the QR code:
 - a. Tap . Aim the camera of the TMX-2050 display at the QR code.
 - b. To scan more than one QR code, tap .
 - c. When you are finished scanning, tap .
 8. To download a license from a USB drive:
 - a. Insert the USB drive into a USB port of the TMX-2050 display.
 - b. Tap .
 - c. Tap on the file explorer. Within the file explorer, go to the USB drive and find the license file you want.
 - d. Tap on the license file. The system applies the license you selected and returns to the App Central *Licenses* screen.
-
-  **CAUTION** – Do not remove the USB drive while the display is writing to or from the drive. This will corrupt the data.
-
9. To enter the license code, tap  and enter the code with the on-screen keyboard.

USB port

The display has two USB ports: one on the side of the display and one on the back of the TMX-2050 display.

You can use a USB drive to transfer data to and from your Precision-IQ field application. See [USB data transfer \(page 64\)](#).



CAUTION – Do not use a USB drive in each USB socket at the same time. If you are attempting to upgrade firmware using a USB drive and another USB drive is already in one of the sockets, the firmware upgrade will fail.

The display senses when a USB drive is inserted into either the side or rear port, and shows the icon  on the top [Status bar \(page 43\)](#).

Insert a USB drive

1. Move the display so you that can see the USB port on the side or back of the display.
2. Pull the rubber cover off the USB port.
3. Insert the USB drive into the USB port. On the [Status bar \(page 43\)](#), a USB icon displays.

Remove USB drive



CAUTION – Do not remove the USB drive while the display is writing to or from the drive. This will corrupt the data.

1. Move the display so you that can see the USB port.
2. Make sure the LED light of the USB drive is not blinking (indicating data transfer is occurring).
3. Pull the USB drive out of the USB port.
4. Press the rubber cover back onto the USB port.

Settings

In this chapter:

About settings	74
About tablet settings	74
Accessibility settings	74
Add account settings	74
Apps settings	75
Backup & reset settings	75
Data usage	75
Display settings	75
Display Units settings	75
ISOBUS settings	76
Language & input settings	76
Location	77
Mapping settings	77
Modem services settings	78
Office Sync settings	79
Patterns settings	80
Printing settings	81
Safety and Alarms settings	81
Security	81
Sounds	82
Steering and guidance settings	83
Storage settings	83
Users settings	84
Users and passwords	85

You can access settings for the display as well as settings for the Precision-IQ field application.

About settings

To access these settings, at the [Menu bar \(page 45\)](#) tap  and select About.

Information	Tap to view...
Software Information	The list of software packets for diagnostics.
Current User Information	System information on the user currently logged in. See Users and passwords (page 85) .
Current Preference Information	The current settings of the user that is currently logged in.
Device Information	Technical information about the display.
Network Information	

About tablet settings

To access these settings, at the [Launcher screen \(page 47\)](#) tap  and select About.

Information	Tap to view...
Status	Status of the battery, network and other information.
Model Number	
Android Version	
Kernel Version	
Build Number	

Accessibility settings

To access these settings, at the [Launcher screen \(page 47\)](#) tap  and select Accessibility.

Add account settings

To access these settings, at the [Launcher screen \(page 47\)](#), tap  and select Add account.

Apps settings

To access these settings, at the [Launcher screen \(page 47\)](#) tap  and select Apps.

Backup & reset settings

To access these settings, at the [Launcher screen \(page 47\)](#) tap  and select Backup & reset.

Data usage

To access these settings, at the [Launcher screen \(page 47\)](#) tap  and select Data usage.

This screen shows the data used by each application.

Display settings

To access these settings, at the [Launcher screen \(page 47\)](#) tap  and select Display.

Setting	Tap to...
Brightness	
Wallpaper	
Daydream	
Font size	
Cast screen	

Display Units settings

To access these settings, at the [Menu bar \(page 45\)](#) tap  and select Display units.

Setting	Tap to...
Display Units	The type of units you want on the display.
Number Format	The format you want on the display.

ISOBUS settings

You can access these settings by tapping  on the [Menu bar \(page 45\)](#) and selecting ISOBUS.

Information	Tap to view...
Enable Universal Terminal	To use Universal Terminal when using ISO-certified equipment, tap OFF to ON to activate this feature. See: <ul style="list-style-type: none"> • Add an ISOBUS implement (page 169) • Universal Terminal operation (page 239)
Enable Task Controller Support	Note – <i>This feature is optional and requires an unlock. See Upgrade or apply a license for new feature (page 70).</i> To use Task Controller for automatic section control when using ISO-certified equipment, tap OFF to ON to activate this feature. See Add an ISOBUS implement (page 169) .
Enable Automatic ISO Configuration Updates	To receive automatic updates on ISO-certified equipment, tap OFF to ON to activate this feature.

Language & input settings

To access these settings, at the [Launcher screen \(page 47\)](#) tap  and select Language & input.

Setting	Tap to view or choose...
Language	
Spell checker	
Personal dictionary	
Default (keyboard)	
Android Keyboard (AOSP)	
Japanese IME	
Text-to-speech output	
Pointer speed	

Location

To access these settings, at the [Launcher screen \(page 47\)](#) tap  and select Location.

Mapping settings

To access these settings, tap  on the [Menu bar \(page 45\)](#) and select Mapping.

These settings control guidance mapping features available on the **Run** screen.

Setting	Tap to view or change...
Map Background Selection	The ground color for the Run screen. Options are: <ul style="list-style-type: none"> • Color: Brown, green or grey • Color with texture • Color with grid lines
Map Color Scheme	Day or night mode.
Map Orientation	Which point of view displays on the Run screen when following the position of the vehicle. Orientation options: North Up or Vehicle Up.
Record Coverage When Engaged	The system can switch on coverage when auto guidance is engaged, and switch off coverage when it is not engaged. Option for this setting is on or off.

Modem services settings

To access modem services settings, go to the [Launcher screen \(page 47\)](#) and tap .

Modem settings include:

- [Modem settings \(page 78\)](#)
- [Network settings \(page 78\)](#)
- [Office Sync settings, 1](#)

Modem settings

Setting	Tap to view or change...
Device Name	The serial number of the DCM-300 modem.

Network settings

Network (CDMA)

Setting	Tap to...
CDMA Reset	Reset the network connection. This will reset the connection between the modem and the service provider, and will remove all existing settings.

The following additional settings that are read only and are automatically completed with the DCM-300 modem connects to the network:

- Mobile Directory Name (MDN)
- Electronic Serial Number (ESN)
- Mobile Identification Number (MIN)
- Preferred Roaming List (PRL)

Also see:

- [Office Sync Diagnostics \(page 274\)](#)
- [Office Sync data transfer \(page 65\)](#)

Network (GSM)

Setting	Tap to...
APN	View the access point name.
SIM PIN	The PIN for the SIM.
Advanced	Launch a displayed message to enter the GSM Username and GSM Password.

The following additional settings that are read only and are automatically completed with the DCM-300 modem connects to the network:

- IMEI: International Mobile Equipment Identity
- SIM ICCID: IMS Charging Identifier
- SIM Status: Status of SIM

Office Sync settings

To access these settings, tap  on the [Menu bar \(page 45\)](#) and select Office Sync.

Setting	Explanation
Office Sync	Turn the feature on or off.
Check Server	Set how often you want the display to attempt to retrieve data from the server.
Send Data	Choose when you want the display to send information to the office: <ul style="list-style-type: none"> • Hourly • On job completion • When display powers up • Prior to shutdown: delays the display's time for powering off
Auto Send Without Prompt	Select whether or not you want the display to send information to the office automatically.

Patterns settings

To access these settings, tap  on the [Menu bar \(page 45\)](#) and select Patterns.

At patterns settings, you can:

- Activate the auto close feature to use when you create boundaries and headlands
- Activate smoothing for curves and turn radius when traveling on guidance lines
- Customize the tight turn warning angle and look-ahead time

Curve Features

Setting	Tap to view or change...
Curve Smoothing	The feature on or off. When curve smoothing is on, the system smooths out the guidance curve, making it wider.
Smooth Turn Radius	The size of the circle that the system will guide to. The larger the circle (degrees), the wider the turn.
Tight Turn Warning Angle	The number of degrees that will trigger a warning about a tight turning angle. See Tight turn warning (page 248) .
Tight Turn Look Ahead Time	The number of seconds before you approach a tight turn angle that the warning will show on the screen. See Tight turn warning (page 248) .

Headlands

Setting	Tap to view or change...
Auto Close	Automatically closes the beginning and end point when you create boundaries and headlands.
Auto Close Distance	The distance between your beginning point and ending point for a headland.

See [Headland and infill pattern creation \(Run screen\) \(page 216\)](#).

Boundaries

Setting	Tap to view or change...
Auto Close	Automatically closes the beginning and end point when you create boundaries.
Auto Close Distance	The distance between your beginning point and ending point for a boundary.
Boundary Smoothing	Turn on or off.

See [Boundary creation \(Run screen\) \(page 210\)](#).

Printing settings

To access these settings, at the [Launcher screen \(page 47\)](#) tap  and select Printing.

Safety and Alarms settings

To access these settings, at the [Menu bar \(page 45\)](#) tap  and select Safety and Alarms.

Setting	Tap to view and set...
Auto Steering Operator Timeout	The amount of time before the Precision-IQ field application disengages auto guidance and stops applications when there is no response to a shutdown message.
Application Control Operator Timeout	The amount of time before the Precision-IQ field application disengages automatic application control when there is no response to a shutdown message.

Security

To access these settings, at the [Launcher screen \(page 47\)](#) tap  and select Security.

Information	Tap to view...
Screen Lock	
Owner info	
Encrypt tablet	
Make passwords visible	
Device administrators	
Verify apps	
Storage type	
Trusted credentials	
Install from storage	
Clear credentials	

Sounds

To access these settings, at the [Launcher screen \(page 47\)](#) tap  and select Sounds.

Setting	Tap to...
Touch sounds	
Screen lock sound	

Steering and guidance settings

To access these settings, tap  on the [Menu bar \(page 45\)](#) and select Steering and Guidance.

Setting	Tap to view or change...
Nudge Increment	The increment used to nudge the guidance system with each tap. You can incrementally nudge a pattern in a perpendicular direction relative to the pattern. Nudging a pattern helps adjust for satellite drift. See Guidance adjustments (page 226) and GNSS and drift (page 107) .
Implement Draft Increment	The increment used to nudge the implement to the current guidance line. See Guidance adjustments (page 226) .
Aggressiveness Increment	The increment used to change aggressiveness. See Steering adjustments (page 206) .
Autosteering Lockout	Whether the feature is on or off. When lockout is on, Precision-IQ application does not offer an option to use auto guidance.
Re-mark Reset with Import	Remove all re-mark entrees on with an import. See Guidance adjustments (page 226) .
End of Row Distance	Distance for the end of row warning to display. See End of row warning (page 248) .
NMEA from Autopilot Diagnostics Port	On: NMEA messages (page 254) can be sent from the NavController. Off: No messages are sent.
Vehicle Direction Detection	Turn on or off
Manual mode heading filter	
Manual mode heading filter bandwidth	
Manual mode steering filter	

Storage settings

To access these settings, at the [Launcher screen \(page 47\)](#) tap  and select Storage.

The system shows the amount of storage used by applications, items on your device and the USB drive if it is inserted.

Users settings

To access these settings, at the [Launcher screen \(page 47\)](#) tap  and select Users.

Users and passwords

To access these settings, at the [Menu bar \(page 45\)](#) tap  and select Users and Passwords.

User profiles and passwords are universal, meaning they are active for both the Precision-IQ field application and FmX Plus.

Setting	Tap to...
Persistent User	
Restore Defaults	
Users	Add and edit users

Add a user

1. Tap **Add User**.
2. Enter the Operator ID.
3. Enter and confirm the user's password.
4. Tap **Create User**.

Take a photo of a user

You can capture a photo of the user, which will display:

- Next to the user's information in the Users and passwords section of Settings
 - On the [Status bar \(page 43\)](#) when the user is logged in
1. At the Users and passwords section, tap the user icon on the right of the user information.
 2. The camera activates and displays a frame on the screen. Make sure the user's face is contained within this frame.
 3. To capture the photo, tap **Capture**. The photo displays on the lower right. You can continue to tap **Capture** until you are satisfied with the photo.
 4. When you are ready to save the photo, tap **Done**.

Connectivity

In this chapter:

GNSS receiver settings	88
DCM-300 modem initial setup	105
Office Sync setup	106
Connectivity concepts	107

In addition to GNSS, you can use optional correction services, the DCM-300 modem, and Office Sync to transfer files to your Connected Farm application.

This chapter contains information regarding setting up connectivity and corrections.

GNSS receiver settings

The TM-200 Module contains a built-in GNSS receiver. To set up the receiver, you choose:

- The type of antenna you are using
- The correction source you will be using, if any

Note – GNSS status will not show a converging or normal status until a vehicle has been configured and selected. See [GNSS notification button \(page 46\)](#).

1. After installing the AG25 GNSS antenna, power on the vehicle. This will power on the receiver.
2. Open the Precision-IQ field application.
3. Make sure all optional features are unlocked and all subscriptions are activated. See [.Upgrade or apply a license for new feature \(page 70\)](#)
4. At the **Home** screen, tap .
5. Tap **GNSS Setup**.

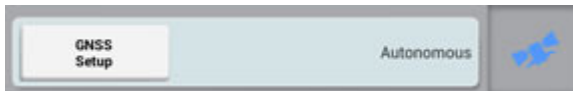

The GNSS setup panel displays.

6. At the SELECTION section:
 - a. Tap **Antenna Type**, then select the antenna you are using from the list. Choices are AG25, Other, Zephyr™ II, Zephyr II (Ruggedized).
 - b. Tap **Correction Source** and select the correction source you will be using.

Note – You will not be able to select any correction source that is locked.

Correction Source	Description
Autonomous (None)	No GPS corrections. If this is your correction source, there are no additional settings for you to enter.
SBAS corrections (page 90)	Satellite-based augmentation systems (SBAS) with free correction services
RangePoint RTX™ See RangePoint RTX corrections (page 91)	Satellite-based subscription service for corrections with pass-to-pass accuracy < 6" (15 cm) and GLONASS compatibility
OmniSTAR® wide-area differential GPS service	Satellite-based subscription service

Correction Source	Description
See OmniSTAR G2/HP/GR corrections setup (page 93)	
CenterPoint™ RTX CenterPoint RTX Modem corrections (page 95)	Cellular broadcast subscription service for corrections with < 1.5" (3.8 cm) accuracy and GLONASS compatibility.
CenterPoint RTX CenterPoint RTX Satellite corrections (page 96)	Satellite broadcast subscription service for corrections with < 1.5" (3.8 cm) accuracy and GLONASS compatibility.
CenterPoint VRS corrections (page 98)	Cellular-broadcast RTK corrections from a ground-based reference station using the a modem. (Requires a DCM-300 modem.)
RTK corrections (page 100)	Radio-broadcast corrections from a ground-based reference station. (Requires the AG-815 integrated radio.)

- c. Tap **Position Quality** to change from the default Favor Accuracy.

Setting	Description
Favor Accuracy (Default)	Use for operations needing highest accuracy.
Balanced Quality	Trades potential accuracy for longer production time.
Favor Availability	Expands production time further with potential for reduced accuracy.

7. Tap  to save your settings.

SBAS corrections

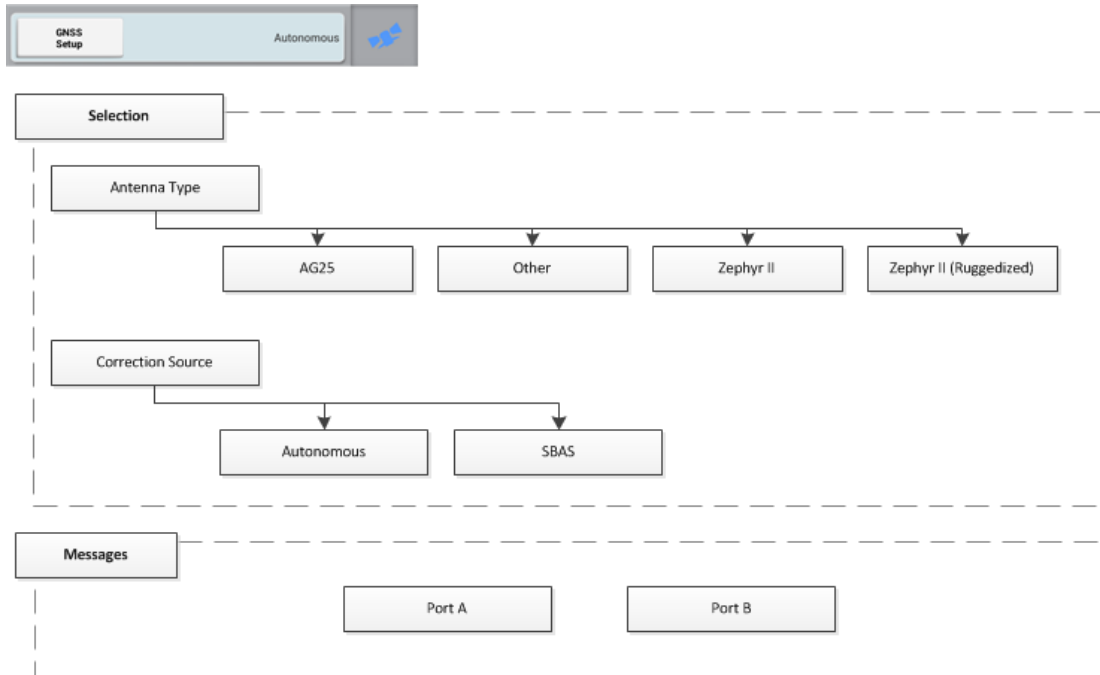

The satellite-based augmentation systems (SBAS) with free correction services are:

- WAAS (Wide Area Augmentation System) in North America
- EGNOS (European Geostationary Navigation Overlay Service) in Europe
- MSAS (Multi-functional Satellite Augmentation System) in Asia Pacific regions

Setting	Options
Correction Satellite Selection	Choose <i>Auto Select</i> for automatic satellite selection, or select a satellite from the list.
Position Quality	Select the appropriate choice: <ul style="list-style-type: none"> • Favor Accuracy (Default) : Use for operations needing highest accuracy (such as row crop planting and strip-till). • Balanced Quality: Trades potential accuracy for longer production time. • Favor Availability: Expands production time further with potential for reduced accuracy.

RangePoint RTX corrections



Requires Unlock – This feature requires a license unlock to set up and use. See [Upgrade or apply a license for new feature \(page 70\)](#).

RangePoint RTX is a satellite-based subscription service for corrections with pass-to-pass accuracy < 6" (15 cm) and GLONASS compatibility.

The GNSS receiver in the TM-200 Module receives these signals.

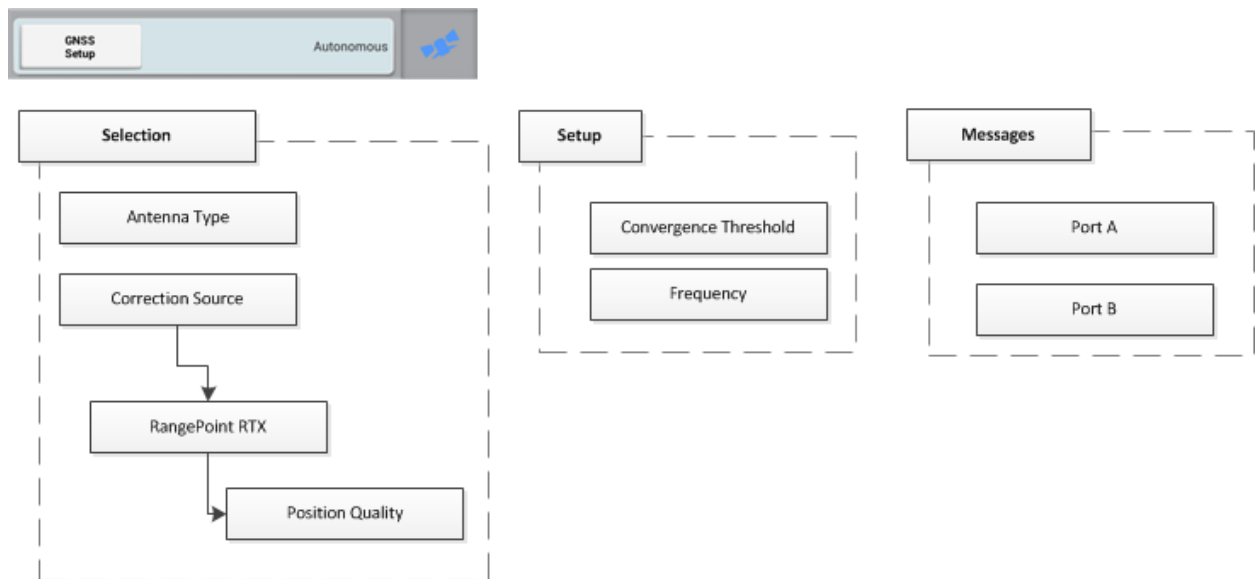

To set up this correction service:

1. Unlock RangePoint RTX. See [Upgrade or apply a license for new feature \(page 70\)](#).
2. At the **Home** screen, tap .
3. Tap **GNSS Setup** to display the setup panel.

Setting	Options
Position Quality	Select the appropriate choice: <ul style="list-style-type: none">• Favor Accuracy (Default) : Use for operations needing highest accuracy (such as row crop planting and strip-till).• Balanced Quality: Trades potential accuracy for longer production time.• Favor Availability: Expands production time further with potential for reduced accuracy.
Convergence Threshold	View the convergence level at which the system will allow you to start guidance operations.
Frequency	Choose the frequency for your region or enter a custom frequency. See Frequency and baud rate (page 104) .

OmniSTAR G2/HP/GR corrections setup



Requires Unlock – This feature requires a license unlock to set up and use. See [Upgrade or apply a license for new feature \(page 70\)](#).

Satellite-based subscription service:

- HP corrections have 2 - 4" (5 - 10 cm) accuracy
- G2 corrections have 3 - 4" (8 - 10 cm) accuracy and is compatible with GLONASS

The GNSS receiver in the TM-200 Module receives these signals.

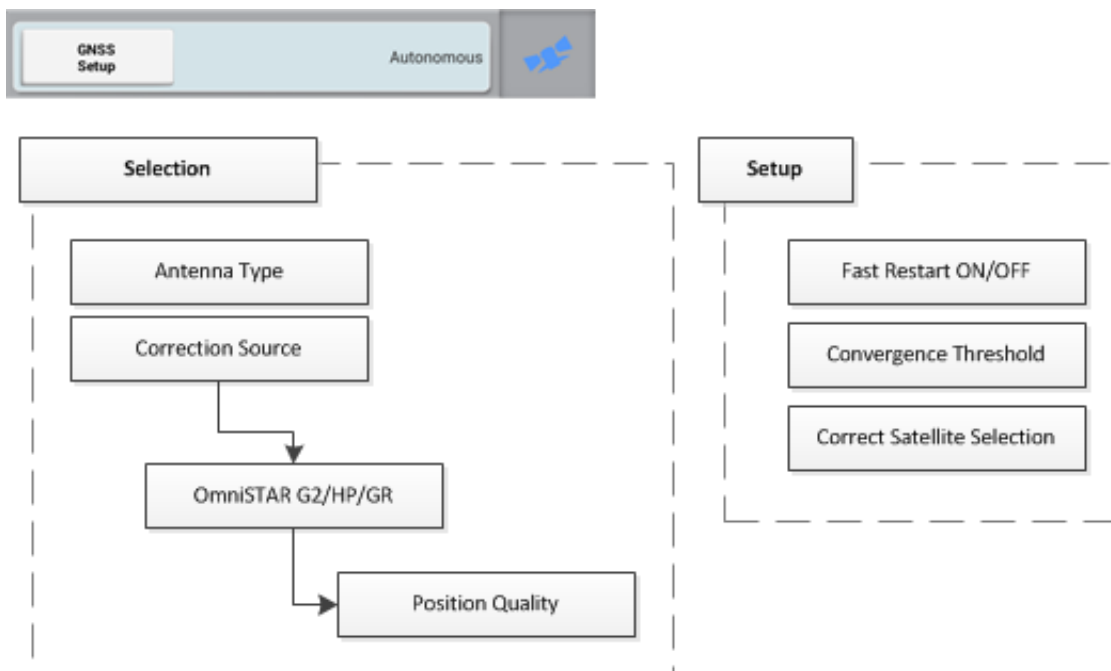

To set up this correction service:

1. Unlock OmniSTAR G2/HP/GR. See [Upgrade or apply a license for new feature \(page 70\)](#).
2. At the **Home** screen, tap .
3. Tap **GNSS Setup** to display the setup panel.

Setting	Options
Position Quality	<p>Select the appropriate choice:</p> <ul style="list-style-type: none"> • Favor Accuracy (Default) : Use for operations needing highest accuracy (such as row crop planting and strip-till). • Balanced Quality: Trades potential accuracy for longer production time. • Favor Availability: Expands production time further with potential for reduced accuracy.
Fast Restart	<p>Choose a Fast Restart option:</p> <ul style="list-style-type: none"> • On (Default): Reduces the time for position to converge so that the system is ready for operation faster. Tap On when the vehicle is parked in an area with a clear view of the sky, and will not be moved until next use. • Off: Does not use Fast Restart.
Convergence Threshold	<p>Set the convergence level at which the system will allow you to start guidance operations.</p> <ul style="list-style-type: none"> • Enter a convergence value closer to 12 inches for broad acre applications to begin working promptly. • Enter a convergence value closer to 4 inches for row crop applications to ensure desired accuracy is achieved before beginning work.
Correction Satellite Selection	<p>Tap <i>Auto Select</i> for automatic satellite selection, or select a satellite from the list. If you choose <i>CUSTOM</i>, enter the Frequency and Baud Rate.</p>

CenterPoint RTX setup



Requires Unlock – This feature requires a license unlock to set up and use. See [Upgrade or apply a license for new feature \(page 70\)](#).

The types of CenterPoint RTX correction are:

- [CenterPoint RTX Modem corrections \(page 95\)](#)
- [CenterPoint RTX Satellite corrections \(page 96\)](#): Standard convergence, fast convergence for US, fast convergence for EU

CenterPoint RTX Modem corrections

CenterPoint RTX Modem / Standard is a cellular broadcast subscription service for corrections with < 1.5" (3.8 cm) accuracy and GLONASS compatibility. The DCM-300 modem receives these signals.

To set up this correction service:

1. Connect the DCM-300 modem to the display.
2. Power on the DCM-300 modem and display by turning on the vehicle ignition.
3. Open the Precision-IQ field application.
4. Unlock CenterPoint RTX. See [Upgrade or apply a license for new feature \(page 70\)](#).
5. Reboot the DCM-300 modem by turning off the vehicle ignition.
6. Turn the vehicle ignition back on.
7. At the **Home** screen, tap .
8. Tap **GNSS Setup** to display the setup panel.

Setting	Options
Position Quality	Select the appropriate choice: <ul style="list-style-type: none"> • Favor Accuracy (Default) : Use for operations needing highest accuracy (such as row crop planting and strip-till). • Balanced Quality: Trades potential accuracy for longer production time. • Favor Availability: Expands production time further with potential for reduced accuracy.
Fast Restart	Turn on or off.
Modem	DCM-300 is the option available.

Setting	Options
Convergence Threshold	<p>Set the convergence level at which the system will allow you to start guidance operations.</p> <ul style="list-style-type: none"> • Enter a convergence value closer to 12 inches for broad acre applications to begin working promptly. • Enter a convergence value closer to 4 inches for row crop applications to ensure desired accuracy is achieved before beginning work.

CenterPoint RTX Satellite corrections

CenterPoint RTX satellite broadcast subscription services for corrections have a < 1.5" (3.8 cm) accuracy and GLONASS compatibility. The RTX satellite corrections available are:

- CenterPoint RTX Satellite Standard
- CenterPoint RTX Satellite Standard Fast for US
- CenterPoint RTX Satellite Standard Fast for EU

The GNSS receiver in the TM-200 Module receives these signals.

To set up any of these correction services:

1. Unlock the appropriate type of convergence for CenterPoint RTX Satellite service. See [Upgrade or apply a license for new feature \(page 70\)](#).
2. At the **Home** screen, tap .
3. Tap **GNSS Setup** to display the setup panel. At the SELECTION tab, complete the settings.

Setting	Options
Antenna Type	Choose the type of antenna you are using.
Correction Source	<p>Choose the appropriate service:</p> <ul style="list-style-type: none"> • CenterPoint RTX Satellite (Standard Convergence) • CenterPoint RTX US Satellite (Fast Convergence) • CenterPoint RTX EU Satellite (Fast Convergence)
Position Quality	<p>Select the appropriate choice:</p> <ul style="list-style-type: none"> • Favor Accuracy (Default) : Use for operations needing highest accuracy (such as row crop planting and strip-till). • Balanced Quality: Trades potential accuracy for longer production time.

Setting	Options
	<ul style="list-style-type: none"><li data-bbox="619 344 1316 414">• Favor Availability: Expands production time further with potential for reduced accuracy.

4. Tap the SETUP tab and complete the setting for frequency. See [Frequency and baud rate \(page 104\)](#).
5. Tap MESSAGING to complete any GNSS CAN message setup. See [CAN message settings \(page 103\)](#).

CenterPoint VRS corrections



Requires Unlock – This feature requires a license unlock to set up and use. See [Upgrade or apply a license for new feature \(page 70\)](#).

CenterPoint VRS is a cellular-broadcast RTK correction service from a ground-based reference station using the a modem. (Requires a DCM-300 modem.)

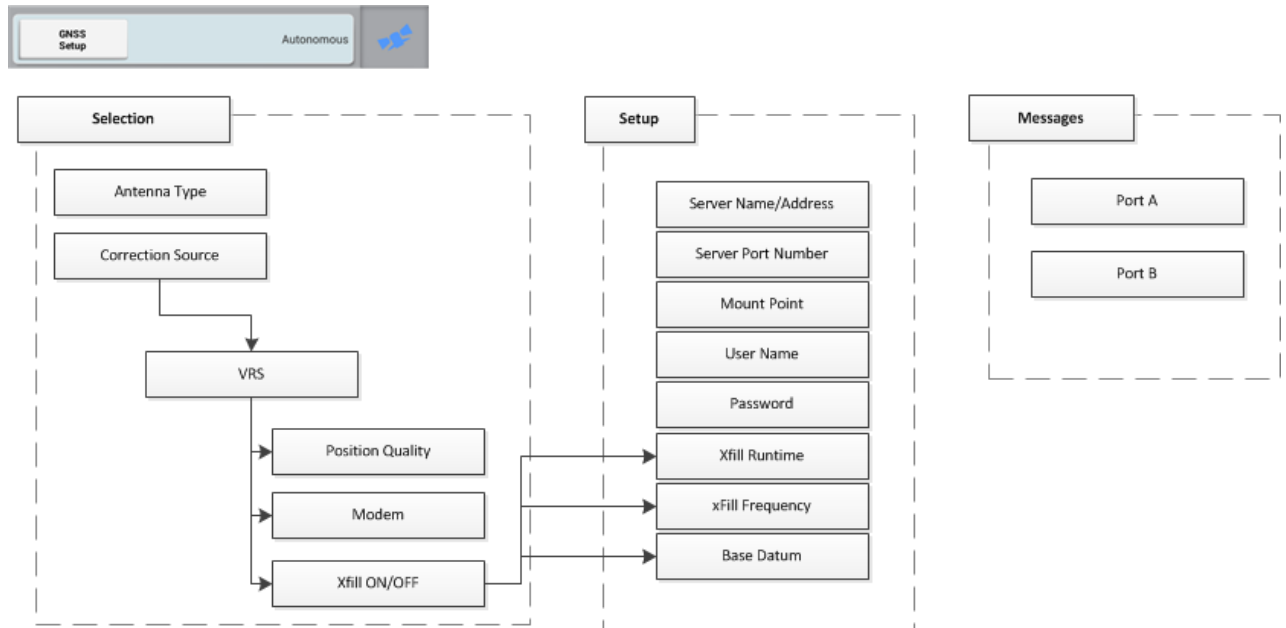

To set up this correction service:

1. Connect the DCM-300 modem to the display.
2. Power on the DCM-300 modem and display by turning on the vehicle ignition.
3. Open the Precision-IQ field application.
4. Unlock VRS. See [Upgrade or apply a license for new feature \(page 70\)](#).
5. Reboot the DCM-300 modem by turning off the vehicle ignition.
6. Turn the vehicle ignition back on.
7. At the **Home** screen, tap .
8. Tap **GNSS Setup** to display the setup panel.

Setting	Options
Modem	<ul style="list-style-type: none"> • DCM-300 • Third Party NTRIP Modem (Cannot be used with Autopilot guidance)
xFill	Turn on or off. See xFill technology (page 107) .
Position Quality	Select the appropriate choice: <ul style="list-style-type: none"> • Favor Accuracy (Default) : Use for operations needing highest accuracy (such as row crop planting and strip-till). • Balanced Quality: Trades potential accuracy for longer production time. • Favor Availability: Expands production time further with potential for reduced accuracy.
VRS Server Name/Address	Enter the value provided by your VRS Service provider.
Server Port Number	Enter the value provided by your VRS Service provider.

RTK corrections

RTK is a radio-broadcast correction service originating from a ground-based reference station, and received by radio signal. The AG-815 integrated radio receives these signals.

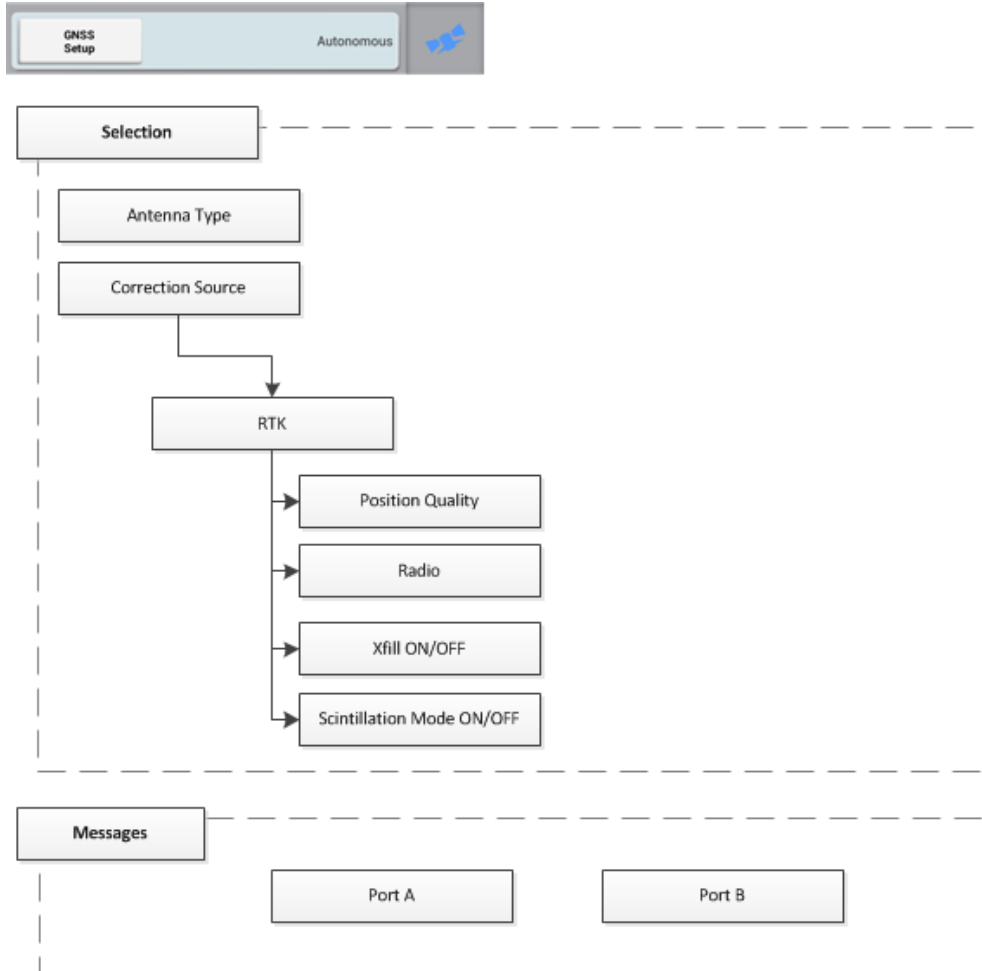

To set up this correction service:

1. Unlock RTK. See [Upgrade or apply a license for new feature \(page 70\)](#).
2. Make sure the AG-815 integrated radio is installed.
3. At the **Home** screen, tap .
4. Tap **GNSS Setup** to display the setup panel.

Setting	Options
Radio	Choose the frequency of the AG-815 integrated radio: 450 MHz or 900 MHz.
xFill	Turn xFill technology on or off. See xFill technology (page 107) .
Scintillation Mode	Turn mode on or off.
Position Quality	Select the appropriate choice: <ul style="list-style-type: none"> • Favor Accuracy (Default) : Use for operations needing highest accuracy (such as row crop planting and strip-till). • Balanced Quality: Trades potential accuracy for longer production time. • Favor Availability: Expands production time further with potential for reduced accuracy.
Channel/Radio Frequency	Tap to show a list of frequencies. If you have already entered frequencies, choose the appropriate one. Otherwise, tap in the row. A Modify button displays. Tap Modify. Enter a number from 403.0 MHz to 473.0 MHz for the frequency Add an optional description. You can enter up to 40 frequencies, numbers and symbols , using up to 9 characters including the decimal place (e.g., 450.00000).
Protocol	<ul style="list-style-type: none"> • PCCEOC 4800 • PCCEOC 9600 • PCCEOT 4800 • PCCEOT 9600 • PCCFST 19200 • PCCSATEL 19200 • TRIMMARK 2 4800 • TRIMMARK 3 19200 • TT450 4800 • TT450 9600 • TT450S 1600 • TT450S 8000
Secure RTK Keys	Enter up to 5 security keys , with an optional description for each.

Setting	Options
xFill Runtime (Available only if you turned on xFill.)	20 minutes. With xFill selected as a backup source, this is how long the display will use xFill after the correction service becomes unavailable.
xFill RTK Base Datum (Available only if you turned on xFill.)	<ul style="list-style-type: none">• WGS84/ ITRF2008 (Default)• NAD83• ETRS89• GDA94

CAN message settings

If you wish to send messages from the GNSS receiver in the TM-200 Module, you can set up what messages will be sent from CAN port A or B. If you are using an ISO-certified implement, use this setting to send information to the implement such as speed.

1. Tap the CAN port that you want to change settings for. Choose the messages for the GNSS receiver in the TM-200 Module to send to ISO-certified equipment.

The list that displays for each CAN port shows the messages and their parameter group number (PGN). For each message, you can choose how often the message is sent:

- Off (never sent)
- 10 Hz, 5 Hz or 1 Hz
- Every 5, 10, 30 or 60 seconds

2. Tap  to save your settings.

1. Open the Universal Terminal from the [Launcher screen \(page 47\)](#) by tapping .

2. In the upper right corner, tap .

3. At the *Universal Terminal Settings* window, turn on the settings appropriate for your setup:
 - GNSS Vehicle Position (PGN 65267)
 - GNSS Vehicle Direction/Speed (PGN 65256)
 - Wheel-based Speed (PGN 65096)
 - Ground-based Speed (PGN 65097)

4. When you are finished, tap .

Frequency and baud rate

The frequencies and baud rates for regions are:

Region	Frequency	Baud Rate
Asia/ Pacific	1539.8325 MHz	600
Central North America	1557.8150 MHz	2400
Eastern North America	1557.8590 MHz	600
Europe/ Africa	1539.9525 MHz	600
Europe (RTX EU)	1529.7250 MHz	2400
Latin America	1539.8325 MHz	600
Western North America	1557.8615 MHz	600

DCM-300 modem initial setup

The DCM-300 modem ships as a locked unit until it is installed with the display.

To use VRS correction or data transfer features, activate and configure these services.

1. Connect the DCM-300 modem to the display.
2. Power on the DCM-300 modem and display.
3. Open the Precision-IQ field application.
4. Activate the required services on the display. See [Upgrade or apply a license for new feature \(page 70\)](#).
 - a. To use VRS corrections, activate [RTK corrections \(page 100\)](#) and [CenterPoint VRS corrections \(page 98\)](#).
 - b. Office Sync also requires activation. See .
5. Reboot the DCM-300 modem by turning off the vehicle ignition.
6. Open the Precision-IQ field application.
7. On the **Home** screen, tap , then tap **Settings**. The system settings screen displays.
8. Tap **Modem Service**.
9. Continue the instructions for setup at [Modem services settings \(page 78\)](#).

Office Sync setup



Requires Unlock – This feature requires a license unlock to set up and use. See [Upgrade or apply a license for new feature \(page 70\)](#).

With the Office Sync service, you can electronically transfer data from Precision-IQ field application to the office and to your Connected Farm account. Data will be:

- Sent to the office based on user settings.
- Received from the office based on user settings, with no inbox needed

Requirements for Office Sync

Requirements for exchanging data electronically include the following:

- A configured DCM-300 modem.
See:
[Modem services settings \(page 78\)](#)
[DCM-300 modem initial setup \(page 105\)](#)
- A Connected Farm account.
- A data plan or access to Wi-Fi.
- Office Sync configured on the display to communicate with your Connected Farm storage area.
See .
See [Modem services settings \(page 78\)](#).

Connectivity concepts

For more information about concepts associated with GNSS, correction services, see:

- [xFill technology \(page 107\)](#)
- [GNSS and drift \(page 107\)](#)
- [VRS \(page 111\)](#)

GNSS and drift

GNSS satellites are in continuous motion as they orbit the earth twice per day in a repeated pattern. Satellites transmit signals that the GNSS receiver translates to determine its position.

While performing field activities, you may notice differences in:

- Where the crop row is
- Where the guidance line was established
- Where the display is indicating the guidance line is now located.

This happens because GNSS satellite constellation patterns change over time and can experience interference.

Local and atmospheric conditions can impact signals. Temperature and humidity can delay signals. Signals can also be reflected from surrounding objects such as trees, causing multiple copies of the signal or a delay in the signal reaching the receiver. Data errors from the satellite can also affect accuracy.

xFill technology

xFill™ technology uses Trimble RTX technology to "fill in" for RTK corrections when there are temporary radio or Internet connection outages. xFill technology is a standard feature and is compatible with the AG25 GNSS antenna. The xFill technology can function with corrections from single-baseline RTK, VRS and CORS systems.

When there is an interruption of the RTK correction signal (either from the radio base station or from the VRS cellular network), the xFill technology performs corrections. xFill technology uses the last-known RTK position combined with the RTX precision satellite data to maintain a high level of horizontal positioning accuracy for up to 20 minutes. There is a smooth transition from RTK to xFill technology and back to RTK.

Automatic guidance systems

If an auto-steering system is engaged using RTK, the auto-steer system will stay engaged during the 20 minute xFill coverage. As soon as an RTK signal is available, the receiver will switch back to the RTK correction service and xFill will remain on standby in the background. If the system cannot

resume an RTK Fixed status within 20 minutes the system will fall back to DGPS correction and the auto-steer system will disengage.

Accuracy

xFill technology can maintain a relatively high level of horizontal accuracy throughout the RTK outage period. However, accuracy is primarily dependent on three factors:

- GNSS satellite availability and obstructions between the satellite and receiver (trees, buildings, and so on)
- Exactness of the base station position
- Length of time since the last RTK position (maximum allowable time is 20 minutes)

If you are concerned with maintaining sub-inch precision, disable the xFill feature.

Estimated accuracy over time while the xFill function has been active (with base station accuracy <20cm) is as follows:

- xFill runtime – no RTK corrections Estimated error
- 1-5 minutes 1-5cm
- 6-10 minutes 5-9cm
- 11-20 minutes 10-15cm

Dependence on satellite

xFill technology requires correction data from at least 5 satellites higher than 10 degrees from the horizon. If GLONASS is unlocked at the RTK level, xFill technology will also be able to use GLONASS satellites. Additionally, large objects such as trees, buildings, and grain bins will significantly decrease or completely block signal reception from all satellite types, including GPS, GLONASS, and corrections satellites. If these same obstructions are between the receiver and the satellite, they may also block xFill signals.



WARNING – Many large and sudden changes in satellite geometry caused by blocked satellites can cause significant position shifts. If operating under these conditions, auto-guidance systems can react abruptly. To avoid possible personal injury or damage to property under these conditions, disable the auto-guidance system and take manual control of the vehicle until conditions have cleared.

Dependence on base station position

When the RTK correction signal is lost, the RTX satellite begins providing correction based on the last RTK position. When you setup xFill and select the datum in which you surveyed your base station, the firmware translates your position into the ITRF datum reference frame to minimize drift. Any other inaccuracies in the base station position can cause a drift in position over time.

As time elapses, correction data from the satellites causes drift from the RTK line. The larger the difference in surveyed base station position, the larger the drift as shown in following table.

The following table shows how the xFill drift over time is impacted by the accuracy of the base station survey coordinates.

xFill Elapsed Time	Survey Accuracy <20cm	Survey Accuracy <2m	Survey Accuracy <5m
0 to 5 min	0 to 5 cm	0 to 15 cm	0 to 25 cm
5 to 15 min	2 cm to 12 cm	10 cm to 0.3 m	15cm to 0.5 m
15 to 20 min	9 cm to 15 cm	15 cm to 0.4 m	0.3m to 0.8 m

If you discover that the surveyed location of your base station is not accurate, your options are:

- Turn off xFill (recommended by Trimble).
- Resurvey your base station. However, this will cause the movement of any stored AB lines that are reloaded/reused which is very undesirable to many RTK customers.

Base station survey

At initial base station installation, Trimble recommends surveying base stations by taking a 24-hour log and processing the data to receive position on your local datum. The accuracy of this position is stated in the report. Over time, primarily due to normal geological events, the base station position may change up to 7cm per year. Please refer to Trimble Support Note on this topic for further information.

When you select the datum used to survey your base station during the xFill technology setup, the receiver will automatically convert your position in the datum you select to the equivalent position in ITRF2008.

If your base station was properly surveyed within the last five years using one of the following coordinate systems, the xFill technology accuracy error will typically be less than 15cm over 20 minutes.

- WGS84/ITRF2008
- NAD83
- ETRS89
- GDA94

When working within an area with several RTK base stations, each base station should have a unique Base ID. When moving in range of another base station, go to the GPS setup on the display and enter the Base ID. This enables the receiver to recognize the new base station.

Base station survey with AutoBase™

If the Trimble Auto Base feature was used to survey the base, the accuracy can be >5m, which decreases the xFill technology accuracy. The datum used for this feature is WGS84. Trimble recommends testing xFill prior to using it in an application where the base station has only been surveyed with Auto Base.

VRS base station

If using VRS, the accuracy is typically <1cm . Contact your VRS network owner to determine the datum used for surveying and enter this datum during the xFill technology set-up. Trimble VRS Now™ network uses the following:

- VRS Now US: NAD83
- VRS Now Europe: ETRS89
- VRS Now TEC Europe: ETRS89
- OmniSTAR® CORS Tasmania: GDA94

Base station, survey unknown

If you do not know if your base station has been surveyed or the datum used for surveying, you should perform testing to approximate your base station errors or turn off xFill technology .

Estimating base station errors

To estimate the error in the position of the base station, options include:

- **Calculate Current Position and Compare to Set Position:** Collect two hours of position logs and submit them for post-processing (using the same coordinate system as previously used). Then enter the current set position and the newly calculated position into a GPS distance tool calculator.
- **xFill Accuracy Detection Using Cross Track Error:** Set-up your antenna and receiver in an open air environment (field or parking lot). Create an A+ line based on your parked position with RTK fixed. Unplug the radio or unplug the DCM-300 modem if using cellular signal. xFill technology will engage. Watch your cross track error (XTE) for a maximum of 20 minutes. Repeat several times. Keep in mind that this static test only tests the error in one direction (N/S or E/W).
- **xFill Accuracy During Passes in a Field:** To best see the drift of the xFill position over time:
Note – This procedure will only be accurate if you have already completed the Roll Calibration for auto-steering. See [Vehicle setup \(page 114\)](#).
 - a. Create an A/B line in your field (or use an existing line). See [AB guidance line creation \(Run screen\) \(page 213\)](#).
 - b. Drive the line and once your cross track error (XTE) is very small, stop and drop a flag in the center of your hitch.
 - c. Turn off RTK by changing the network ID or frequency.
 - d. Drive around the field for several minutes (to represent your typical outage time) and return to the A/B line.
 - e. Engage on the line and then when XTE is small and you're over your previous flag, stop and drop another flag. Compare the distance.

- f. Make a pass in the other direction on the same A/B line and drop a third flag. Compare the distance.

When not to use xFill technology

xFill technology is not recommended for:

- Land leveling and water management applications where a high degree of vertical accuracy is required.
- Any operation where you need accuracy better than 1" (2.4cm).
- When the base station has not been properly surveyed, or has been surveyed only with the Auto Base functionality and no tests have been performed to assess the risk of using xFill technology with that base station.

VRS

VRS™, an integrated system available with a subscription, is complementary to RTK and provides RTK corrections over a large geographic area, where robust cellular data coverage is available. Network processing ensures high accuracy throughout the whole coverage area.

VRS consists of:

- GPS/GNSS reference stations spread out over a large area, typically 30-45 miles (50-70 km) apart.
- A central server that uses Trimble proprietary software to create a correction model for the region covered by the network. GPS rovers communicate using a cell modem with the VRS server and receive RTK type corrections. The data from the reference stations is used to model errors throughout your region. The model is used to:
 - Create a network of virtual reference stations near your current location.
 - Provide a localized set of standard format correction messages for your roving receiver. Since the error models are updated every second, all rovers receive an optimal correction model after connecting on to the network. This ensures a high quality correction, and accuracy.

Network solution

All reference stations used in a VRS system can be interpreted as a network of continuously operated reference stations. The difference between VRS and CORS is that VRS provides a network solution. The position accuracy is maintained even if you move away from the single base but are still within the network.

Due to the longer range, fewer base stations can cover a greater region. Additionally, VRS networks may offer better signal coverage in rough terrain if the local cellular network is robust and provides good data coverage.

Vehicles

In this chapter:

Vehicle setup	114
Add a vehicle	115
Delete a vehicle	116
Edit a vehicle	117
Save a vehicle	117
Vehicle summary	118
Select a vehicle	119
Manual guidance setup	120
Autopilot system setup	121
OnSwath	126
Autopilot system calibration	127
EZ-Pilot system setup	145
EZ-Pilot system calibrations	149
EZ-Steer system setup	152
EZ-Steer system calibrations	155

You can add, edit, save, delete and select vehicles. Part of vehicle setup includes entering settings for auto guidance systems, providing vehicle measurements and calibrating the vehicle with the guidance system.

You must select a vehicle to be able to enter a field.

Vehicle setup

On-screen vehicles in the Precision-IQ field application represent actual vehicles, and include basic information about your vehicle as well as its type of guidance system and calibrations.

Note – Prior to using a vehicle for field activities, you must complete all settings for a vehicle, including calibrations. Then you must select the vehicle.

Vehicles can be:

- Added. See [Add a vehicle \(page 115\)](#).
- Saved in a partial or complete state. See [Save a vehicle \(page 117\)](#).
- Removed. See [Delete a vehicle \(page 116\)](#).
- Changed. See [Edit a vehicle \(page 117\)](#).
- Viewed in a summary form. See [Vehicle summary \(page 118\)](#).
- Selected for use in field activities. See [Select a vehicle \(page 119\)](#).

Overview of setup

An overview of the steps for setting up a vehicle includes selecting the GNSS receiver and entering measurements.

An overview of the steps for setting up a vehicle includes:

1. Selecting the vehicle type and entering basic vehicle information:
 - Guidance type: Manual, Autopilot, EZ-Pilot or EZ-Steer
 - For the Autopilot and EZ-Steer systems, navigation controller orientation: How the controller is oriented in the vehicle
 - For the EZ-Pilot system: How the label is facing on the IMD-600
 - Measurements: Measurements for the location of the antenna and other vehicle measurements
2. Calibrating the guidance system with the vehicle.

Add a vehicle

Note – You must complete all vehicle setup and calibration steps before you can select and use the vehicle for field activities on the **Run** screen.

- At the **Home** screen, tap . The Vehicle setup panel displays.



- Tap **ADD VEHICLE**. A list of vehicle types displays.



- Tap the type of vehicle to set up.
- To enter information about the vehicle's make, model and so on, tap **Next**.

Note – Only vehicles on the current Trimble supported platforms for Autopilot, EZ-Pilot, and EZ-Steer list are in the database. Generic vehicles are selectable for each vehicle type for manual guidance.

Tap...	To enter or select...
Make	Vehicle manufacturer
Series	Vehicle series (when applicable)
Model	Vehicle model
Option	Vehicle options from the manufacturer (Examples: Super Steer, Non Super Steer, ILS, Non-ILS, or ISO CAN Ready)
Vehicle Name	The name of the vehicle is pre-filled from the options you chose for Make, Series, and Model. You can optionally change this name if you wish.

- Tap **Next**. The SELECTION section displays. The receiver serial number is displayed, indicating the GNSS receiver in the TM-200 Module is receiving signals.

Confirm that this is the proper serial number for the TM-200 Module attached to the Precision-IQ field application. When moving displays between vehicles, this is not automatically updated.

6. Tap **Next**. A list of steering/guidance types displays. The choices will depend on the vehicle:
 - Autopilot
 - EZ-Pilot
 - EZ-Steer
 - Manual Guidance
7. Tap the type of guidance system the vehicle uses.
8. Continue entering settings for the vehicle and guidance system. For instructions, see the section that applies to your guidance system:
 - [Autopilot system setup \(page 121\)](#)
 - [EZ-Pilot system setup \(page 145\)](#)
 - [EZ-Steer system setup \(page 152\)](#)
 - [Manual guidance setup \(page 120\)](#)



WARNING – Auto guidance systems cannot avoid items in the field such as obstacles. Make sure you are adequately trained to operate the auto guidance system.

For instructions on saving the vehicle, see [Save a vehicle \(page 117\)](#).



Delete a vehicle



CAUTION – If you delete a vehicle, all information about the vehicle will be erased.

1. At the **Home** screen, tap . The Vehicle setup panel displays.





2. On the left-hand side in the list, tap the name of the vehicle you want to delete.
3. On the right-hand side, tap **Delete**. A confirmation message displays asking you to confirm removal of the vehicle.
4. To delete, tap . You return to the Vehicle setup panel at the **Home** screen.
5. To cancel the deletion, tap .

Edit a vehicle

1. At the **Home** screen, tap . The Vehicle setup panel displays.



2. At the VEHICLES list on the left-hand side of the setup panel, tap the name of the vehicle you want to edit. The application changes the list item to a blue background with white text.
3. On the right-hand side, tap **Edit**. The SUMMARY section displays.
4. Navigate to the section(s) where you want to make changes.
5. After you have completed your changes, tap **SUMMARY**.
If you have not completed all the required information, you can save the edits you made. However, you cannot use the vehicle on the **Run** screen.
6. When you are finished, tap **SUMMARY**. Tap  to save your settings.
7. To discard the changes and leave the vehicle setup panel, tap . A message displays, asking if you want to cancel without saving your changes. Tap cancel.

For details on the vehicle summary, see [Vehicle summary \(page 118\)](#).

For information on guidance system types, see the applicable section:

- [Autopilot system setup \(page 121\)](#)
- [EZ-Pilot system setup \(page 145\)](#)
- [EZ-Steer system setup \(page 152\)](#)
- [Manual guidance setup \(page 120\)](#)

Save a vehicle

You can save:

- Complete vehicle settings after reviewing the SUMMARY section. For details on the vehicle summary, see [Vehicle summary \(page 118\)](#).
- Unfinished vehicle settings, then complete the setup later.

If you have not completed all the required information, you can save the edits you made. However, you cannot use the vehicle profile in field activities on the **Run** screen.

Save a complete vehicle profile

1. Complete all vehicle settings, including calibration.
2. At the SUMMARY section, tap . The application saves the vehicle and returns to the Vehicle setup panel.



Save an incomplete vehicle profile

Note – You must complete all vehicle setup and calibration steps before you can use the vehicle for field activities on the **Run** screen.

1. At a minimum, enter some basic information: vehicle type, make and model.
2. At the SUMMARY section, tap . The application saves the vehicle and returns to the Vehicle setup panel at the **Home** screen.

Vehicle summary



The SUMMARY section of a vehicle profile contains the vehicle information and configurations. Incomplete information will be noted as "Incomplete".

To...	Tap...
Save the vehicle with any changes you have made.	
Exit the setup without saving changes. The application will ask you to either save the changes or exit without saving.	 on the System bar (page 44)

Select a vehicle

Before you can calibrate a vehicle or enter the **Run** screen, you must select the vehicle you want to use for field activities.

Note – You can only enter the **Run** screen with a vehicle that has had vehicle setup and calibration steps completed.

1. At the **Home** screen, tap . The Vehicle setup panel displays.
2. At the list on the left-hand side of the setup panel, tap the name of the vehicle you want to select. The application changes the list item to a blue background with white text.
3. To select the vehicle before performing field activities at the **Run** screen, tap **Select**. The name of the vehicle highlights in blue and the  indicates which vehicle you chose.



Note – Without a blue highlight, the  indicates a vehicle that was selected previously.

4. The application indicates in the lower left-hand portion of the screen which vehicle is selected for field activities.

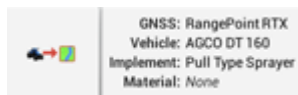

Manual guidance setup

1. Navigate to the GUIDANCE section of the vehicle setup panel:
 - a. At the **Home** screen, tap . The Vehicle setup panel displays.
 - b. At the list on the left-hand side of the setup panel, tap the name of the vehicle you want to edit. The display changes the list item to a blue background with white text.
 - c. Tap **Edit**, then **GUIDANCE**.
2. Tap **Selection**, then tap **Manual Guidance**.

Autopilot system setup



Requires Unlock – This feature requires a license unlock to set up and use. See [Upgrade or apply a license for new feature \(page 70\)](#).

Settings for the Autopilot system include:

- The type of platform for the Autopilot system
- The origin of the vehicle profile
- Controller and sensor settings
- Vehicle measurements
- Calibrations

Guidance system settings for Autopilot system



WARNING – Auto guidance systems cannot avoid items in the field such as obstacles. Make sure you are adequately trained to operate the auto guidance system.

1. Navigate to the GUIDANCE section of the vehicle setup panel:
 - a. At the **Home** screen, tap . The Vehicle setup panel displays.
 - b. At the list on the left-hand side of the setup panel, tap the name of the vehicle you want to edit. The display changes the list item to a blue background with white text.
 - c. Tap **Edit**, then **GUIDANCE**.
2. At the SELECTIONS section, complete the settings:

Tap...	Explanation
Selection	Autopilot
Autopilot Platform	The appropriate platform for your vehicle.
Vehicle Profile Origin	The source of the vehicle profile: <ul style="list-style-type: none"> • Vehicle Profiles Database: contained in the display • Import from Navigation controller: If your navigation controller has already been set up for a different Trimble display, the vehicle profile is stored in the controller.

Tap...	Explanation
⚠	<ul style="list-style-type: none"> Import from USB: profile stored on USB drive (These configuration / .cfg files are located in the AgData/Profiles folder on the USB drive.) See USB VDB transfer (page 66). <hr/> <p>CAUTION – If you select a <i>Vehicle Profile</i> that is not suitable for your vehicle, you may experience degraded system performance.</p> <hr/>
GNSS Setup Selection	If you have not completed GNSS setup. See GNSS receiver settings (page 88) .
Configure GNSS	Setup GNSS if you have not already done so.

⚠ **WARNING** – Many large and sudden changes in satellite geometry caused by blocked satellites can cause significant position shifts. If operating under these conditions, auto-guidance systems can react abruptly. To avoid possible personal injury or damage to property under these conditions, disable the auto-guidance system and take manual control of the vehicle until conditions have cleared.

3. Tap **Next** to continue to [Controller settings for Autopilot system \(page 122\)](#).

Controller settings for Autopilot system

The navigation controller indicates to the Precision-IQ field application how your vehicle is positioned. To set up the controller, you must indicate the position/orientation of the controller as it is currently installed in the vehicle.

For example, if the controller is positioned with the input jacks of the controller facing to the left side of your vehicle, you indicate this in the Precision-IQ field application.

The CONTROLLER SETTINGS section of the vehicle setup panel shows an image of the controller as though you are looking down on the vehicle from above, with the front of the vehicle at the top of the screen.

1. Navigate to the GUIDANCE section of the vehicle setup panel:
 - a. At the **Home** screen, tap . The Vehicle setup panel displays.
 - b. Tap **Edit**.
 - c. At the list on the left-hand side of the setup panel, tap the name of the vehicle you want to edit. The display changes the list item to a blue background with white text.
 - d. Tap **Edit**, then **GUIDANCE**.
2. Tap **CONTROLLER SETTINGS**.

3. Rotate the on-screen controller to match the position of the actual controller in the vehicle as you are looking down from the top, with the nose of the tractor point to the top of the screen. Tap the arrow buttons to move the on-screen navigation controller clockwise or counterclockwise.

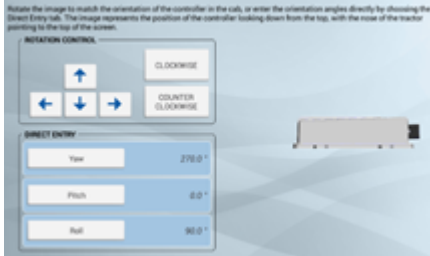

4. Optionally you can directly enter the degrees of the position by tapping **Yaw**, **Pitch** and **Roll**. Non-orthogonal entries will not show the orientation on the display.
5. When the controller position on the screen matches the controller installed in the vehicle, continue to the sensor settings. See [Sensor settings for Autopilot system \(page 123\)](#).

Sensor settings for Autopilot system

Note – Adjust sensor settings only if necessary to improve steering performance.

1. Navigate to the **GUIDANCE** section of the vehicle setup panel:
 - a. At the **Home** screen, tap . The Vehicle setup panel displays.
 - b. Tap **Edit**.
 - c. At the list on the left-hand side of the setup panel, tap the name of the vehicle you want to edit. The display changes the list item to a blue background with white text.
 - d. Tap **Edit**, then **GUIDANCE**.
2. Tap **SETTINGS**. Complete the information at the SETTINGS section.

Note – Not all setting items will be available for all vehicles. Setting items are only available to the applicable vehicle types.

Tap...	To...
Steering Sensor	Select the type of angle sensor installed on the vehicle: <ul style="list-style-type: none"> • Potentiometer • AutoSense™ device
AutoSense Location	Select the location of the AutoSense device: <ul style="list-style-type: none"> • Left Wheel • Right Wheel

Tap...	To...
AutoSense Orientation	Indicate the direction the AutoSense label is facing: <ul style="list-style-type: none"> • Label Up • Label Down <p>Note – If the orientation is not accurate, assisted steering may be affected.</p>
Valve On Speed	Select speed. For vehicles operating at very slow speeds, select Low or Ultra Low. <ul style="list-style-type: none"> • Normal - 1.3 ft/s (0.4 m/s) • Low - 0.3 ft/s (0.1 m/s) • Ultra Low - 0.07 ft/s (0.02 m/s)

Vehicle measurements for Autopilot system

Note – For Autopilot guidance with untracked or tracked vehicles, **do not** change vehicle measurements unless they are not correct.

At MEASUREMENTS, you can enter and access the measurements that apply to the vehicle type you selected. In addition to measurements of the vehicle itself, measurements related to the antenna location are important for accuracy.

- Before you take measurements:
 - Park the vehicle on level ground.
 - Make sure the vehicle is straight, with the center line of the body parallel to the wheels.
- Navigate to the MEASUREMENTS section of the vehicle setup panel:
 - At the **Home** screen, tap . The Vehicle setup panel displays.
 - Tap **Edit**.
 - At the list on the left-hand side of the setup panel, tap the name of the vehicle you want to edit. The display changes the list item to a blue background with white text.
 - Tap **Edit**, then **GUIDANCE**.
- Tap **MEASUREMENTS**. Based on your selections up to this point, some measurements will be pre-filled.

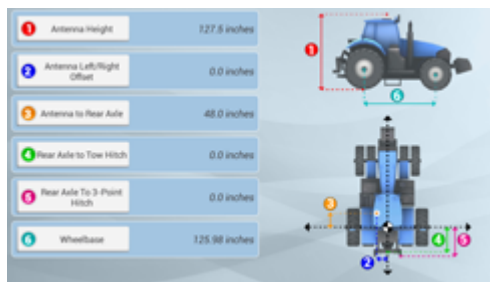

4. Confirm all pre-filled measurements and enter the others.

For the Antenna Height, measure the distance from the ground to the base of the GPS receiver (or antenna).

OnSwath

With OnSwath™, you can customize line acquisition to the vehicle, operation and operator preference. Vehicle behavior during line acquisition is more controlled, more predictable, and more repeatable.

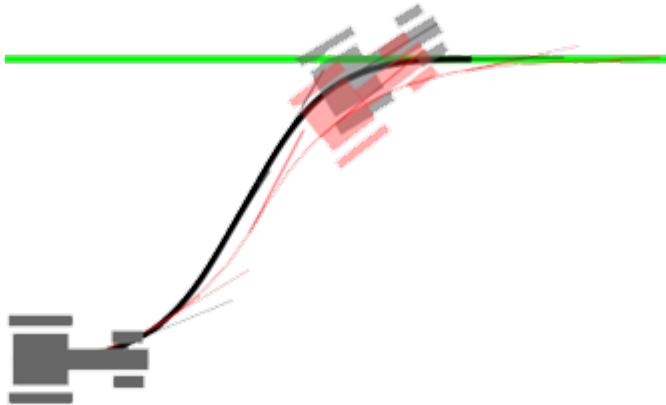

The benefits of OnSwath include:

- Up to 50% faster line acquisition
- Separate tuning for online and line acquisition
- More repeatable performance
- Consistent performance over entire speed range.
- Cab shake eliminated on articulated machines
- Limited turn rates reduce impact on field for tracked machines
- Front axle/nose overshoots more, so that the
- Rear axle on the guidance line faster due to front axle/nose overshooting more

To set up and use OnSwath, see the *Autopilot Toolbox II Guide* and complete calibrations.

OnSwath requires:

- Autopilot firmware 6 and higher
- Autopilot Toolbox II version 3 or higher

Autopilot system calibration

The calibration process for the Autopilot system records additional details about your vehicle, which helps the system to steer the vehicle more accurately. For high accuracy systems, you must have all the correct calibrations.

Note – Currently CAT hydraulic installation Challenger vehicles and John Deere Tracked vehicles using the SIU-200 Interface box cannot be calibrated with the Precision-IQ field application.

The CALIBRATION section lists only the calibrations required for the selected vehicle and steering system.

Note – Calibration is only complete when all calibrations on the screen show results instead of Incomplete. Prior to performing calibrations ensure you completed the steps to [Controller settings for Autopilot system \(page 122\)](#).

1. Remove any implement from the vehicle. Drive the vehicle to an open area free of obstacles in which the vehicle can make long passes (400m/.25 mile).
2. At the Vehicle setup panel, select the vehicle you want to work with. See for detailed instructions.
3. Tap **Calibrate**. The display shows **only** the calibrations required for the vehicle you have selected.
4. Perform each of the calibration procedure selections presented. Following the on-screen instructions when applicable. More detailed information on each calibration follows.
5. When you are finished, tap  to save the calibrations.

Calibration for non-tracked vehicles

Calibration	Explanation
Manual override sensitivity calibration (page 129) Note – For vehicles that use a pressure transducer or column encoder for the manual override.	Adjusts how much force is required to disengage the system when the driver turns the steering wheel. Note – The system detects whether the vehicle configuration includes this type of sensor. This option only appears if required.
Automated steering deadzone calibration (page 133) Note – Only for front wheel steered and articulated vehicles.	For learning the vehicle’s steering dead zones. Determines the minimum valve command required for steering movement.
Proportional steering gain (page 137)	Sets the proportional gain to control steering overshoot and responsiveness.

Calibration	Explanation
Steering sensor calibration (page 131) <i>Note – Only for vehicles with a potentiometer style steering sensor.</i>	Converts the voltage output of the steering angle sensor into an equivalent steering angle measurement.
Line acquisition (page 143)	Controls how fast the guidance system attempts to steer the vehicle onto the current guidance line (50% - 150%).
Engage aggressiveness (page 144)	How aggressively the vehicle initially engages on the guidance line (50% - 150%).
Roll correction calibration (page 139)	Compensates for minor variations in the placement of the navigation controller and GNSS antenna.

Also see [Autopilot system diagnostics \(page 252\)](#).

Manual override sensitivity calibration

WARNING – Incorrect adjustment of *Manual Override Sensitivity* could cause this critical safety feature to fail, resulting in personal injury or damage to the vehicle. Do not to choose a setting that is either too sensitive or not sensitive enough. It is vital to avoid setting the sensitivity so low that the system will not detect any steering wheel motion.

Note – This control is for platforms that use a pressure transducer or encoder for manual override. The software detects whether or not the system uses this type of sensor.

One way to disengage the Autopilot system is to turn the steering wheel or manually override automatic steering. When you turn the steering wheel, there is a voltage spike that then tapers off. This spike and decline occurs at different levels for different models of tractor.

Manual Override Sensitivity sets the level that the voltage must reach before the guidance system disengages. The voltage must also drop below that level before automated steering can be engaged again.

A high level of sensitivity causes the system to disengage more quickly, and you must wait longer before you can re-engage. A low level of sensitivity causes the system to take longer to disengage, and you will be able to re-engage more quickly.

1. At the Vehicle setup panel, select the vehicle you want to work with. See [Select a vehicle \(page 119\)](#) for detailed instructions.
2. Tap **Calibrate**.
3. Tap **Manual Override Sensitivity**. The system displays the calibration tool.



4. Turn the steering wheel. If the threshold is crossed, the steering wheel will change color.
5. If the disengage response is acceptable, tap  and then perform the next calibration.
6. If the response is **not** acceptable, and:
 - a. The system disengages too easily, move the slider bar to the right to increase the value and decrease the sensitivity.
 - b. The system seems hard to disengage, move the slider bar to the left to decrease the value and increase the sensitivity.

Note – The default setting provides a balance between rapid activation of the override function and rejection of steering wheel motion due to incidental contact (for example, due to travel in a rough field).

- c. Repeat steps 4 and 5 until the disengage response is acceptable.



Tip – Evaluate *Manual Override Sensitivity* under conditions which may affect the pressure of the hydraulic system. For example, turn on the auxiliary hydraulics while you evaluate the sensitivity.

7. Tap **X** to exit without saving. The display returns to the CALIBRATION section where you can perform another calibration or exit.

Steering sensor calibration

Steering sensor calibration converts the voltage output of the steering angle sensor into an equivalent steering angle measurement.

Note – *Steering sensor calibration is only for platforms with a rotary potentiometer installed.*

Note – *Complete this calibration before you attempt the [Automated steering deadzone calibration \(page 133\)](#) or [Roll correction calibration \(page 139\)](#) calibrations.*

1. Drive the vehicle to a field with a hard, level surface without obstructions.
2. At the Vehicle setup panel, select the vehicle you want to work with. See [Select a vehicle \(page 119\)](#) for detailed instructions.
3. Tap **Calibrate**.
4. Tap **Steering Sensor**. The calibration tool displays.
5. Read the instructions and tap the **Next**.
6. Steer straight ahead and drive forward slowly. Maintain a tractor speed above 1.6 kph (1 mph). Tap **Next**.
7. Turn the steering wheel all the way to the left and continue moving forward.
 - a. Note the sensor voltage value.
 - b. While the steering wheel is at the full left position, tap **Next**.
8. Turn the steering wheel all the way to the right.
 - a. Note the sensor voltage value.
 - b. While the steering wheel is at the full right position, tap **Next**.
9. Steer straight ahead and drive for a while to ensure you are traveling straight.
10. Check the value. The center should be approximately 2.5 volts. The calibration process attempts to map the values for a full left turn, a full right turn and center steering.
 - a. Note the sensor voltage value.
 - b. When the vehicle is going straight, press **Next**.
11. Turn the steering wheel to full left and full right.
 - a. Check that the voltage value and degree value does not stop changing before the steering articulation hits the end stops.
 - b. Ensure that the full left turn and the full right turn are at approximately the same value.
 - c. If the values are not approximately symmetrical, tap **X** to discard the calibration and repeat step 6 through step 9. The steering sensor may require adjustment or replacement if:

The value...	Outcome
For sensor volt	Not symmetrical for full left and full right turns
For degrees	Not near 0
For voltage	Stops changing before the articulation of the steering is to the full left or full right position

12. Tap  to accept the calibration.
13. To restart the calibration, tap **Steering Sensor**.

Automated steering deadzone calibration

The *Automated Deadzone* calibration runs a series of tests on the valve and steering hydraulics to determine the steering signal where steering movement occurs. It determines the minimum valve command required for steering movement when you direct the vehicle to turn to the right or left.

In this test, the system independently calibrates both sides of the steering system to determine the point at which wheel movement occurs for each direction.

Note – Large obstacles or terrain variation may cause erratic steering position readings which may degrade the calibration done smooth, level surface recommended for this calibration.



WARNING – During the Deadzone calibration, the system moves the vehicle's steering wheel. To avoid injury, be prepared for sudden vehicle movement.

Pre-calibration steps

Complete these steps **before** you begin calibration:

1. Complete the vehicle profile steps for setup.
2. Warm up the vehicle. The hydraulic fluid must be at normal operating temperature for deadzone calibration.

Note – On some vehicles with large reservoirs, it may take a longer amount of time for the fluid to reach operating level, especially if the implement circuit is lightly loaded. Consult the vehicle documentation to determine if the hydraulic fluid temperature can be shown on a vehicle console.

3. If you perform the deadzone calibration while the system is cold, repeat both the Automated Deadzone and Steering Gain calibrations again when the system is at operating temperature. See [Proportional steering gain \(page 137\)](#).
4. Prepare the steering sensor:
 - a. If the vehicle has an AutoSense device, drive the vehicle in a straight line for at least one minute.
 - b. If the vehicle has a Potentiometer, complete the *Steering Sensor* calibration first. See [Steering sensor calibration \(page 131\)](#).

Calibration steps

1. Drive the vehicle to a large field without hazards or obstructions. The field should have smooth soil that is loose but firm.



CAUTION – Obstacles in the field can cause collisions, which may injure you and damage the vehicle. If an obstacle in the field makes it unsafe to continue the Automated Deadzone calibration, stop the vehicle and turn the steering wheel to disengage the system.

- 1) Wait until the Precision-IQ field application prompts you that the phase is ready to begin.
- 2) Look at the screen to determine whether the next phase will require a left or right turn.
- 3) Reposition the vehicle so that the turn will use the space that you have available.
- 4) Tap the button to begin the next phase.

2. At the Vehicle setup panel, select the vehicle profile you want to work with. See [Select a vehicle \(page 119\)](#) for detailed instructions.
3. On the left-hand side, tap **Calibrate**.
4. Tap **Automated Steering Dead Zone**. The calibration panel displays.
5. Center The steering and tap **Next**.
6. Read each instruction and then tap **Next**.
7. Center the steering on the tractor and move forward in first gear at high RPM for at least five seconds.
8. Tap **Test Right** and continue moving forward while the system performs a coarse right side test.
9. When the test is finished, center the steering again and drive forward for five seconds.
10. Tap **Test Left** and continue moving forward while the system performs a coarse left side test.
11. Tap **Accept** to accept the calibration. The system displays the AutoPilot calibration panel again.
12. Continue driving ahead slowly and tap **Test Right**. The system will perform the first right hand fine calibration.
13. Repeat the right and left hand fine calibrations until there is a change of less than .5 in each of the deadzone values

To minimize the total amount of space needed for the complete calibration, you can reposition the vehicle between each calibration process. If available flate, smooth space is extremely limited, re-align the vehicle after each calibration.

Note – If you encounter any error messages during calibration, refer to the [Automated Deadzone error messages](#) in this section.

Automated Deadzone error messages

Message: Error -	Explanation
Manual Override Detected	Manual override was detected before the calibration cycle could be completed. Retry the calibration.
No GPS	A GNSS receiver must be connected and outputting positions before the software can run the calibration procedure.

Message: Error -	Explanation
No Steering Response Detected	During the calibration cycle, there was not enough movement for the calibration to complete. If the problem persists, the hydraulic installation could be faulty.
Software Problem Detected	The software was unable to complete the calibration due to insufficient movement of the vehicle. If the problem persists, contact Technical Support.
Steering Close To End Stops	Before the calibration cycle could be completed, the measured steering angle approached the end stops. Retry, and if the problem persists, instead of centering the steering at the start of each cycle, try turning the steering in the opposite direction to that which is being tested so that the calibration procedure has a greater range to test over.
Unable To Determine DZ: Try Again	A problem occurred when trying to compute dead zone. Retry. If the problem persists, contact Technical Support.
Valve Connectors Could Be Swapped	The calibration test sensed the steering turning in the opposite direction to what was expected. Retry. If the problem persists, either the valve connectors have been accidentally swapped or the steering sensor calibration was performed incorrectly.
Vehicle Moving Too Slow	The vehicle was moving too slowly for the calibration cycle to successfully finish. Make sure the vehicle is moving at least 0.8 kph (0.5 mph) during each calibration cycle.

Calibration steps

1. Drive the vehicle to a large field without hazards or obstructions. The field should have smooth soil that is loose but firm.



CAUTION – Obstacles in the field can cause collisions, which may injure you and damage the vehicle. If an obstacle in the field makes it unsafe to continue the Automated Deadzone calibration, stop the vehicle and turn the steering wheel to disengage the system.

- 1) Wait until the Precision-IQ field application prompts you that the phase is ready to begin.
- 2) Look at the screen to determine whether the next phase will require a left or right turn.
- 3) Reposition the vehicle so that the turn will use the space that you have available.
- 4) Tap the button to begin the next phase.

2. At the Vehicle setup panel, select the vehicle profile you want to work with. See [Select a vehicle \(page 119\)](#) for detailed instructions.
3. On the left-hand side, tap **Calibrate**.

4. Tap **Automated Steering Dead Zone**. The calibration panel displays.
5. Center the steering and tap **Next**.
6. Read each instruction and then tap **Next**.
7. Center the steering on the tractor and move forward in first gear at high RPM for at least five seconds.
8. Tap **Test Right** and continue moving forward while the system performs a coarse right side test.
9. When the test is finished, center the steering again and drive forward for five seconds.
10. Tap **Test Left** and continue moving forward while the system performs a coarse left side test.
11. Tap **Accept** to accept the calibration. The system displays the AutoPilot calibration panel again.
12. Continue driving ahead slowly and tap **Test Right**. The system will perform the first right hand fine calibration.
13. Repeat the right and left hand fine calibrations until there is a change of less than .5 in each of the deadzone values

To minimize the total amount of space needed for the complete calibration, you can reposition the vehicle between each calibration process. If available flat, smooth space is extremely limited, re-align the vehicle after each calibration.

Note – If you encounter any error messages during calibration, refer to the [Automated Deadzone error messages](#) in this section.

Automated Deadzone error messages

Message: Error -	Explanation
Manual Override Detected	Manual override was detected before the calibration cycle could be completed. Retry the calibration.
No GPS	A GNSS receiver must be connected and outputting positions before the software can run the calibration procedure.
No Steering Response Detected	During the calibration cycle, there was not enough movement for the calibration to complete. If the problem persists, the hydraulic installation could be faulty.
Software Problem Detected	The software was unable to complete the calibration due to insufficient movement of the vehicle. If the problem persists, contact Technical Support.
Steering Close To End Stops	Before the calibration cycle could be completed, the measured steering angle approached the end stops. Retry, and if the problem persists, instead of centering the steering at the start of each cycle, try turning the steering in the opposite direction to that which is being tested so that the calibration procedure has a greater range

Message: Error -	Explanation
	to test over.
Unable To Determine DZ: Try Again	A problem occurred when trying to compute dead zone. Retry. If the problem persists, contact Technical Support.
Valve Connectors Could Be Swapped	The calibration test sensed the steering turning in the opposite direction to what was expected. Retry. If the problem persists, either the valve connectors have been accidentally swapped or the steering sensor calibration was performed incorrectly.
Vehicle Moving Too Slow	The vehicle was moving too slowly for the calibration cycle to successfully finish. Make sure the vehicle is moving at least 0.8 kph (0.5 mph) during each calibration cycle.

Proportional steering gain

Note – Adjust the steering gain only when the Autopilot system performance is less than satisfactory.

Proportional steering gain (PGain) balances rapid steering response and stability. PGain affects the following:

- Slew Time: The amount of time that the front wheels take to move from the far left to the far right position and back.
- Overshoot: The percentage by which the front wheels exceed the commanded angle before they settle on the correct value.

High Gain	Low Gain
Decreases the slew time and increase the overshoot. This provides rapid responses, but can cause the steering to exhibit signs of instability (for example, a tendency to excessively overshoot).	Increases the slew time and decrease the overshoot. This improves the stability but can introduce delays in the steering response and can cause the vehicle to oscillate from side to side.



Pre-calibration steps

1. Complete the vehicle setup steps.
2. Perform calibration for the Automated Deadzone. See [Automated steering deadzone calibration \(page 133\)](#) before you perform the calibration for steering gain.
3. Drive the vehicle to an open area with a smooth surface.



CAUTION – The wheels can move abruptly during the Steering Proportional Gain procedure while the Autopilot system tests the hydraulic response to its steering commands. To avoid injury, be prepared for vehicle movement.

Calibration steps

1. At the Vehicle setup panel, select the vehicle you want to work with. See [Select a vehicle \(page 119\)](#).
2. Tap **Calibrate**, then tap **Steering Proportional Gain**. The calibration tool displays.
3. Tap **Run Slew Test**. To proceed with the test, tap **Next**.
4. Drive forward at 1 mph (1.6 kph) or faster. Tap **Next**.
5. Turn the front wheels completely to the right and then tap **Turn Left**. Drive forward while the vehicle turns left, until the screen shows the test is complete.
6. Turn the front wheels completely to the left and then tap **Turn Right**. Drive forward while the vehicle turns right, until the screen shows the test is complete.
Note – With some vehicles, valve size and hydraulic capabilities of the machine will limit the slew time. In such cases, optimizing the P-gain value will be difficult.
7. Note the Slew Time and Overshoot values.
8. Adjust the gain value.
9. Repeat step 3 through step 8 until the Gain is just below the level where any one of the following occurs:
 - Slew times no longer decrease (a low value is required some vehicles too high gain is possible - 1500-2000 milliseconds is ideal).
 - Overshoot exceeds 5 – 8% (depending on the vehicle).
 - Wheels noticeably shake near end stops.
10. When you find the optimum gain, tap  to accept the calibration or  to exit without saving. The display returns to the CALIBRATION section where you can perform another calibration or exit.

Roll correction calibration

Roll correction compensates for minor variations in the placement of the navigation controller and GNSS antenna.

Note – If you use multiple GNSS technologies (for example, RTK and WAAS), then use the device with the highest accuracy when calibrating roll correction. For best results, use RTK, RTX or OmniSTAR HP with a signal that has been converged for at least 20 minutes. If you complete roll calibration with less accurate correction, repeat the steps below at least four times for greater accuracy.

Pre-calibration steps

1. Set up a vehicle and perform all calibrations preceding this one.
2. Read and understand the instructions provided below for the calibration procedure.
3. Remove any implement from the vehicle and drive it to a flat, smooth area where you can complete passes of at least 400 ft (125 m) in length.
4. Create a field. See [Add a field \(page 160\)](#).

Calibration steps

1. Select the vehicle and implement you want to work with.
See [Select a vehicle \(page 119\)](#) and [Select an implement \(page 182\)](#) for detailed instructions.
2. Select a field and enter the **Run** screen.
See [Select a field \(page 161\)](#) and [Enter a field \(Run screen\) \(page 162\)](#).
3. Create a new, straight guidance line.
See [AB guidance line creation \(Run screen\) \(page 213\)](#) or [A+ guidance line creation \(Run screen\) \(page 214\)](#).
4. Make sure the on-screen lightbar is displayed on the screen.
See [On-screen widgets \(page 244\)](#).
5. Engage automatic steering on the line. Drive until the on-screen lightbar number is as close to zero as possible, and then stop the vehicle.
6. Mark the vehicle's position:
 - a. Place the vehicle in park and exit the cab.
 - b. Place a flag in the ground that will mark the vehicle's center line. Use the drawbar pin hole or use another feature of the vehicle as a reference point.

On vehicles such as sprayers, swathers, or combines, determine a reference point in the center of the vehicle to mark (preferably near to the reference location for the antenna

such as front axle, rear axle, or center of track rotation).

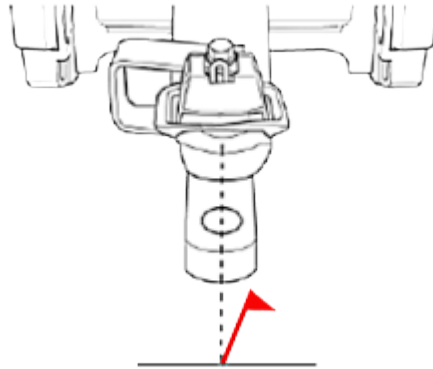

7. Re-enter the cab and continue to drive down the guidance line.
8. Turn the vehicle around and then re-engage **on the same line** in the opposite direction.
9. Stop the vehicle with the drawbar (or other feature used to mark the center line of the vehicle) as close to the first flag as possible.
10. Mark the vehicle's position.
 - a. Place the vehicle in park and exit the cab.
 - b. Place a second flag in the ground to mark the vehicle's center line.
 - c. Measure the distance between flag 1 and flag 2 and note it.

Distance between flag 1 and flag 2 (step c):

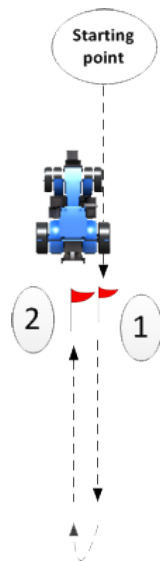

d. Also note where the vehicle's current position is in

Vehicle is to right or left of flag 2

relation to flag 1 (in other words, the vehicle is either to the right or left of flag 1). The diagram, this example shows the vehicle is to the left of flag 1.

(step d):

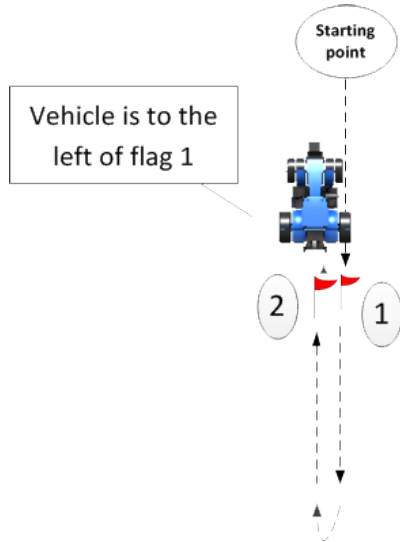

e. Return to the cab and in the **Run** screen note the cross-track error (the number on the on-screen lightbar).

Cross-track error (number on Run screen) (step e):



f. Note the direction highlighted on the lightbar (left or right).

Direction highlighted on lightbar (left or right) (step f):

11. On the [Menu bar \(page 45\)](#), tap  and then tap **Diagnostics**.
12. Tap Autopilot performance and tap the Advanced tab.
13. At the Roll Offset entry box and Vehicle Position selection box:
 - Calculate the roll offset and enter it in the display.
Refer to your notes and compare them to the following table to determine how to calculate roll offset.
 - Determine the direction of the Vehicle Position and enter it on the display.
Refer to your notes and compare them with the following table to find which Vehicle Position to select.

Current vehicle position is to the _____ of flag 1	Lightbar highlight is on the:	Calculate Roll Offset value:	Lightbar (cross-track) value is _____ than flag distance value	Vehicle Position selection
Right	Right	Flag distance minus Cross-track value	Less	Right
Right	Right	Flag distance minus Cross-track value	Greater	Left
Left	Left	Flag distance minus Cross-track value	Less	Left
Left	Left	Flag distance minus Cross-track value	Greater	Right
Right	Left	Flag distance plus Cross-track value	N/A	Right
Left	Right	Flag distance plus Cross-track value	N/A	Left

14. Pull both flags out of the ground and continue driving down the line.
15. Turn the vehicle around again so that you are traveling in the same direction as you were when you originally set the line.
16. Repeat the steps starting at Step 4 until the two flags are under 1" (2.54 cm) apart.

Line acquisition

Line acquisition controls how fast the guidance system attempts to steer the vehicle onto the current guidance line (50% - 150%).

- With a high setting, the vehicle approaches the line quickly, but may overshoot the line and drive into instability.
- With a low setting, the vehicle steers onto the line more slowly, but is less likely to overshoot the line.

Note – Exceeding the capability of the tractor will cause instability (such as oscillating back and forth up and down the line) during line acquisition.

1. Go to Diagnostics:
 - a. On the [Menu bar \(page 45\)](#), tap  and then tap **Diagnostics**.
 - b. Under the Autopilot heading in the left-hand list, tap **Performance**.
 - c. Tap **Steering** at the top of the screen.
 - d. The display shows the tool for calibrating line approach aggressiveness and the cross-track error diagram.
2. Enter the **Run** screen and engage automatic steering on a straight guidance line.
 - a. At the Vehicle setup panel, select the vehicle and implement you want to work with. See [Select a vehicle \(page 119\)](#) and [Select an implement \(page 182\)](#) for detailed instructions.
 - b. Select a field and enter the **Run** screen. See [Select a field \(page 161\)](#) and [Enter a field \(Run screen\) \(page 162\)](#).
 - c. Create a new, straight guidance line. See [AB guidance line creation \(Run screen\) \(page 213\)](#) or [A+ guidance line creation \(Run screen\) \(page 214\)](#).
3. Drive until the lightbar shows that the cross-track error value is as close to zero as possible, and then stop the vehicle.
4. Open the Diagnostics section for Autopilot performance again.
5. Evaluate the current accuracy of the vehicle during line acquisition with the default setting.
6. Touch and move the button with the percentage to move the slider to the left or right. Drive forward and re-engage auto-steering if necessary to test the setting.

Engage aggressiveness

Engage aggressiveness controls how aggressively the vehicle initially turns towards the guidance line.

- With a high setting, the vehicle will initially respond quickly.
 - With low setting, the vehicle will respond more smoothly when initially engaged.
1. Enter the **Run** screen and engage automatic steering on a straight guidance line. See [Enter a field \(Run screen\) \(page 162\)](#) for more instructions on entering the **Run** screen.
 2. Drive the vehicle approximately 10 seconds.
 3. Open the Diagnostics section for the Autopilot system's performance.
 - a. On the [Menu bar \(page 45\)](#), tap  and then tap **Diagnostics**.
 - b. Tap **Steering** at the top of the screen.
 4. Evaluate the current accuracy of the vehicle during line acquisition with the default setting .
 5. Touch and move the button with the percentage to move the slider to the left or right. Drive forward and re-engage auto-steering if necessary to test the setting.

EZ-Pilot system setup



Requires Unlock – This feature requires a license unlock to set up and use. See [Upgrade or apply a license for new feature \(page 70\)](#).

The EZ-Pilot system turns the steering wheel for you with an electric motor drive. It uses GNSS guidance from the Precision-IQ field application.

Initial setup steps are:

- [Guidance selection for the EZ-Pilot system \(page 145\)](#)
- [Controller settings for EZ-Pilot system \(page 145\)](#)
- [Vehicle measurements for EZ-Pilot system \(page 148\)](#)
- [Steering speed settings for EZ-Pilot system \(page 146\)](#)

Guidance selection for the EZ-Pilot system



WARNING – Auto guidance systems cannot avoid items in the field such as obstacles. Make sure you are adequately trained to operate the auto guidance system.

1. Navigate to the **GUIDANCE** section of the vehicle setup panel:
 - a. At the **Home** screen, tap . The Vehicle setup panel displays.
 - b. At the list on the left-hand side of the setup panel, tap the name of the vehicle you want to edit. The display changes the list item to a blue background with white text.
 - c. Tap **Edit**, then **GUIDANCE**.
2. At the SELECTION section, tap EZ-Pilot.



WARNING – Many large and sudden changes in satellite geometry caused by blocked satellites can cause significant position shifts. If operating under these conditions, auto-guidance systems can react abruptly. To avoid possible personal injury or damage to property under these conditions, disable the auto-guidance system and take manual control of the vehicle until conditions have cleared.

3. Tap **Next** to set up the controller orientation. See [Controller settings for EZ-Pilot system \(page 145\)](#).

Controller settings for EZ-Pilot system

The EZ-Pilot system uses the IMD-600 to provide roll compensation when the vehicle is on a slope or drives over a bump. For roll compensation to work correctly, the IMD-600 must be calibrated. IMD

stands for Inertial Measurement Device.

To set up the IMD-600 controller, you must indicate the position/orientation of the controller as it is currently installed in the vehicle.

For example, if the controller is positioned with the input jacks of the controller facing to the left side of your vehicle, you indicate this in the Precision-IQ field application.

The CONTROLLER SETTINGS section of the vehicle setup panel shows an image of the controller as though you are looking down on the vehicle from above, with the front of the vehicle at the top of the screen.

1. Navigate to the **GUIDANCE** section of the vehicle setup panel:
 - a. At the **Home** screen, tap . The Vehicle setup panel displays.
 - b. Tap **Edit**.
 - c. At the list on the left-hand side of the setup panel, tap the name of the vehicle you want to edit. The display changes the list item to a blue background with white text.
 - d. Tap **Edit**, then **GUIDANCE**.
2. Tap **CONTROLLER SETTINGS**.
3. Rotate the on-screen IMD-600 to match the position of the actual IMD-600 in the vehicle as you are looking down from the top, with the nose of the tractor point to the top of the screen. Tap the arrow buttons to move the on-screen IMD-600 clockwise or counterclockwise.



Steering speed settings for EZ-Pilot system

Note – Adjust settings only if necessary to improve steering performance.

1. Navigate to the GUIDANCE section of the vehicle setup panel:
 - a. At the **Home** screen, tap . The Vehicle setup panel displays.
 - b. At the list on the left-hand side of the setup panel, tap the name of the vehicle you want to edit. The display changes the list item to a blue background with white text.
 - c. Tap **Edit**, then **GUIDANCE**.
2. Tap **SETTINGS**. Complete the information at the SETTINGS section.

Setting	Explanation
Angle per Turn	<p>The angle that the wheels turn during one full rotation of the steering wheel (1 - 150 degrees):</p> <ul style="list-style-type: none"> • Too high - the system turns the wheel too little and the vehicle will not hold the line • Too low - results in small, fast oscillations in steering <p>Note – Angle per Turn should be determined by running the automated calibration. The value can then be adjusted here.</p>
Freeplay Left	The amount of free movement in the steering when starting a left turn (0 - 11.9 inches / 0 - 30 cm)
Freeplay Right	The amount of free movement in the steering when starting a right turn (0 - 11.9 inches / 0 - 30 cm)
Steering Delay	<p>The amount of time between steering wheel movement and vehicle yaw rate change (0.1 - 2 seconds).</p> <p>Note – This setting should only be used for swathers and sprayers.</p>
Motor Speed	<p>The speed at which the motor will operate: Auto, Auto High, Auto Low, Auto Maximum, Auto Medium, High, Low, Maximum, Medium</p> <p>Note – Default selection varies depending on vehicle type.</p>
Motor Direction	Reverse mount, standard mount
External Switch	Select a switching option if an external switch is connected to the system: Disabled (Default), Remote Engage, Seat Disengage, Seat Engage Only
Engage Options	Maximum Speed, Minimum Speed, Maximum Angle, Engage Offline, Disengage Offline Override Sensors
Advanced	<p>Note – Do not adjust the Advanced Settings. Advance Settings are provided for support and advanced troubleshooting only.</p> <p>Settings include: Roll Offset Angle, Estimated Steering Angle Bias, Dynamic Approach Angle, Steering Acceleration Limit, Steering Slew Limit</p>

Vehicle measurements for EZ-Pilot system

At MEASUREMENTS, the measurements that apply to the vehicle type you selected are shown in this section. In addition to measurements of the vehicle itself, measurements related to the antenna location are important for accuracy.

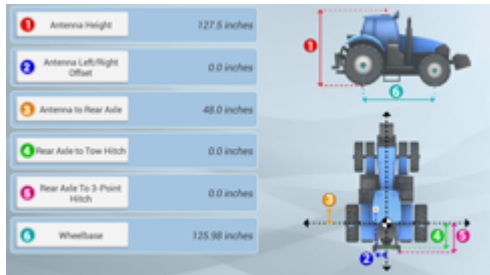

To edit measurements, tap each measurement button and enter the appropriate number.

Before you take measurements:

- Park the vehicle on level ground.
- Make sure the vehicle is straight, with the center line of the body parallel to the wheels.



EZ-Pilot system calibrations

Calibrations for the EZ-Pilot guidance system are:

- [Angle per turn calibration for EZ-Pilot system \(page 149\)](#)
- [Roll correction for EZ-Pilot system \(page 149\)](#)
- [Online aggressiveness calibration for EZ-Pilot system \(page 150\)](#)
- [Line acquisition calibration for EZ-Pilot system \(page 150\)](#)

Also see [EZ-Pilot system diagnostics \(page 257\)](#).

Roll correction for EZ-Pilot system

1. Park the vehicle and mark the center lines of both the front and rear wheelbases on the ground.
2. Navigate to the GUIDANCE section of the vehicle setup panel:
 - a. At the **Home** screen, tap . The Vehicle setup panel displays.
 - b. At the list on the left-hand side of the setup panel, tap the name of the vehicle you want to calibrate. The display changes the list item to a blue background with white text.
3. Tap **Calibrate**.
4. Tap **Roll Calibration**. The calibration tool displays.
5. Follow the instructions on the calibration tool.
6. To accept the calibration, tap .
7. To discard the calibration and start it again, tap **X**.

Angle per turn calibration for EZ-Pilot system

Note – Complete the roll correction calibration before performing this calibration.

1. Navigate to the GUIDANCE section of the vehicle setup panel:
 - a. At the **Home** screen, tap . The Vehicle setup panel displays.
 - b. At the list on the left-hand side of the setup panel, tap the name of the vehicle you want to calibrate. The display changes the list item to a blue background with white text.
2. Tap **Calibrate**.

3. Tap **Angle Per Turn**. The calibration tool displays.
4. Follow the steps on the calibration tool.

Online aggressiveness calibration for EZ-Pilot system

Online aggressiveness controls how aggressively the vehicle reacts to cross track error while operating on the guidance line (50% - 150%).

- With a high setting, the vehicle will be more reactive to cross track error. A high setting may cause the system to overreact and become unstable.
 - With low setting, the vehicle will make less of a steering correction to the online cross track error.
1. Enter the **Run** screen and engage automatic steering on a straight guidance line. See [Enter a field \(Run screen\) \(page 162\)](#) for more instructions on entering the **Run** screen.
 2. Drive the vehicle approximately 10 seconds.
 3. Open the Diagnostics section for the EZ-Pilot system's performance.
 - a. On the [Menu bar \(page 45\)](#), tap  and then tap **Diagnostics**.
 - b. Tap **Steering** at the top of the screen.
 4. Evaluate the current accuracy of the vehicle during online operation with the default setting .
 5. Touch and move the button with the percentage to move the slider to the left or right. Drive forward and re-engage auto-steering if necessary to test the setting.

Line acquisition calibration for EZ-Pilot system

Line acquisition controls how fast the guidance system attempts to steer the vehicle onto the current guidance line (50% - 150%).

- With a high setting, the vehicle approaches the line quickly, but may overshoot the line and drive itself to instability.
- With a low setting, the vehicle steers onto the line more slowly, but is less likely to overshoot the line.

Note – *Exceeding the capability of the tractor will cause instability (such as oscillating back and forth up and down the line) during line acquisition.*

1. Go to Diagnostics:
 - a. On the [Menu bar \(page 45\)](#), tap  and then tap **Diagnostics**.
 - b. Under the EZ-Pilot heading in the left-hand list, tap **Performance**.
 - c. Tap **Steering** at the top of the screen.

- d. The display shows the adjustments for calibrating line approach aggressiveness and the cross-track error diagram.
2. Enter the **Run** screen and engage automatic steering on a straight guidance line.
 - a. At the Vehicle setup panel, select the vehicle and implement you want to work with. See [Select a vehicle \(page 119\)](#) and [Select an implement \(page 182\)](#) for detailed instructions.)
 - b. Select a field and enter the **Run** screen. See [Select a field \(page 161\)](#) and [Enter a field \(Run screen\) \(page 162\)](#).
 - c. Create a new, straight guidance line. See [AB guidance line creation \(Run screen\) \(page 213\)](#) or [A+ guidance line creation \(Run screen\) \(page 214\)](#).
3. Drive until the lightbar shows that the cross-track error value is as close to zero as possible, and then stop the vehicle.
4. Open the Diagnostics section for Autopilot performance again.
5. Evaluate the current accuracy of the vehicle during line acquisition with the default setting.
6. Touch and move the button with the percentage to move the slider to the left or right. Drive forward and re-engage auto-steering if necessary to test the setting.
7. Drive until the lightbar shows that the cross-track error value is as close to zero as possible, and then stop the vehicle.
8. Open the Diagnostics section for EZ-Pilot performance again.
9. Evaluate the current accuracy of the vehicle during line acquisition with the default setting.
10. Touch and move the button with the percentage to move the slider to the left or right. Drive forward and re-engage auto-steering if necessary to test the setting.

EZ-Steer system setup



Requires Unlock – This feature requires a license unlock to set up and use. See [Upgrade or apply a license for new feature \(page 70\)](#).

The EZ-Steer system turns the steering wheel for you by combining a friction wheel and a motor with guidance from the Precision-IQ field application.

Initial setup steps are:

- [Guidance selection for EZ-Steer system \(page 152\)](#)
- [Controller settings for EZ-Steer system \(page 153\)](#)
- [Steering and speed settings for EZ-Steer system \(page 153\)](#)
- [Vehicle measurements for EZ-Steer system \(page 154\)](#)

Guidance selection for EZ-Steer system



WARNING – Auto guidance systems cannot avoid items in the field such as obstacles. Make sure you are adequately trained to operate the auto guidance system.

1. Navigate to the **GUIDANCE** section of the vehicle setup panel:
 - a. At the **Home** screen, tap . The Vehicle setup panel displays.
 - b. At the list on the left-hand side of the setup panel, tap the name of the vehicle you want to edit. The display changes the list item to a blue background with white text.
 - c. Tap **Edit**, then **GUIDANCE**.
2. At the SELECTIONS section, tap **Selection** and then tap EZ-Steering.



WARNING – Many large and sudden changes in satellite geometry caused by blocked satellites can cause significant position shifts. If operating under these conditions, auto-guidance systems can react abruptly. To avoid possible personal injury or damage to property under these conditions, disable the auto-guidance system and take manual control of the vehicle until conditions have cleared.

3. Tap **Next** to set up the controller orientation. See [Controller settings for EZ-Steer system \(page 153\)](#).

Controller settings for EZ-Steer system

Setting	Explanation
Connector Faces	Indicate how the connector on the navigation controller faces: Back, Floor, Front

Steering and speed settings for EZ-Steer system

Note – Adjust settings only if necessary to improve steering performance.

1. Navigate to the GUIDANCE section of the vehicle setup panel:
 - a. At the **Home** screen, tap . The Vehicle setup panel displays.
 - b. At the list on the left-hand side of the setup panel, tap the name of the vehicle you want to edit. The display changes the list item to a blue background with white text
 - c. Tap **Edit**, then **GUIDANCE**.
2. Tap **SETTINGS**. Complete the information at the SETTINGS section.

Steering Sensor Setting	Description
Angle per Turn	<p>The angle that the wheels turn during one full rotation of the steering wheel (1 - 150 degrees):</p> <ul style="list-style-type: none"> • Too high - the system turns the wheel too little and the vehicle will not hold the line • Too low - results in small, fast oscillations in steering <p>Angle per turn values should be calibrated first using EZ-Steer calibration and then adjusted here if necessary.</p>
Freeplay Left	The amount of free movement in the steering when starting a left turn (0 - 11.9 inches / 0 - 30 cm)
Freeplay Right	The amount of free movement in the steering when starting a right turn (0 - 11.9 inches / 0 - 30 cm)
Steering Delay Note – Only available if vehicle is sprayer or swather.	<p>The amount of time between steering wheel movement and vehicle yaw rate change (0.1-1.5 seconds)</p> <p>Note – This value should only be used for swathers and sprayers.</p>
Motor Speed	<p>The speed at which the motor will operate:</p> <ul style="list-style-type: none"> • <i>Auto, Auto Low, Auto Medium, Auto High, or Auto Maximum</i>

Steering Sensor Setting	Description
	<ul style="list-style-type: none"> Manual Low, Manual Medium (Default), Manual High, or Manual Maximum <p>Note – Auto mode determines the proper speed for the steering action required.</p>
Motor Direction	<p>The direction the EZ-Steer system motor is installed:</p> <ul style="list-style-type: none"> Standard Mount Reversed Mount
External Switch	<p>Select a switching option if an external switch is connected to the system:</p> <ul style="list-style-type: none"> Disabled (Default) Seat Disengage Seat Engage Only Remote Engage
Advanced	<p><i>Advanced</i> settings include:</p> <ul style="list-style-type: none"> Roll OffsetAngle Estimated Steering Angle Bias Dynamic Approach Angle Steering acceleration limit Steering slew limit <p>Note – Do not adjust the Advanced Settings. Advance Settings are provided for support and advanced troubleshooting only.</p>

Vehicle measurements for EZ-Steer system

At MEASUREMENTS, you can enter and access the measurements that apply to the vehicle type you selected. In addition to measurements of the vehicle itself, measurements related to the antenna location are important for accuracy.



To enter measurements, tap each measurement button and enter the appropriate number.

Before you take measurements:

- Park the vehicle on level ground.
- Make sure the vehicle is straight, with the center line of the body parallel to the wheels.

For the Antenna Height, measure the distance from the ground to the base of the GPS receiver (or antenna).



EZ-Steer system calibrations

Calibrations for the EZ-Steer auto guidance system include:

- [Angle per turn calibration for EZ-Steer system \(page 155\)](#)
- [Roll correction for EZ-Steer system \(page 155\)](#)

Also see [EZ-Steer system diagnostics \(page 262\)](#).

Roll correction for EZ-Steer system

1. Park the vehicle and mark the center lines of both the front and rear wheelbases on the ground.
2. Navigate to the GUIDANCE section of the vehicle setup panel:
 - a. At the **Home** screen, tap . The Vehicle setup panel displays.
 - b. At the list on the left-hand side of the setup panel, tap the name of the vehicle you want to calibrate. The display changes the list item to a blue background with white text.
3. Tap **Calibrate**.
4. Tap **Roll Calibration**. The calibration tool displays.
5. Follow the instructions on the calibration tool.
6. To accept the calibration, tap .
7. To discard the calibration and start it again, tap .

Angle per turn calibration for EZ-Steer system

Perform the Roll calibration before performing the angle per turn calibration.

1. Navigate to the GUIDANCE section of the vehicle setup panel:
 - a. At the **Home** screen, tap . The Vehicle setup panel displays.
 - b. At the list on the left-hand side of the setup panel, tap the name of the vehicle you want to calibrate. The display changes the list item to a blue background with white text.
2. Tap **Calibrate**.
3. Tap **Angle Per Turn**. The calibration wizard displays.
4. Begin the steps on the calibration procedure by driving the vehicle between 2 and 4 mph.

Fields

In this chapter:

Field Basics	158
Add a field	160
Select a field	161
Enter a field (Run screen)	162
Edit a field (Field Manager)	163

You can create multiple fields and then select one to enter. Using the Field Manager, you can also edit and delete fields.

Field Basics

A field is an item you create in the **Run** screen that represents an area of land. A field can contain one or more boundaries (perimeters) (or no boundaries). Information associated with each field includes:

- Boundaries, guidance lines and patterns for steering assistance
- Landmarks such as points, lines and area features
- Tasks
- Coverage information recorded during field activities when logging is activated
- Attributes such as Clients and Farms

To edit and refine boundaries, guidance lines and patterns, and landmarks, open the [Field Manager \(page 56\)](#).

Boundaries

The perimeter around your field is a boundary. A boundary line begins when you tap a button to record the start of your boundary. After driving the length of the boundary, you tap a button to stop recording the path of the boundary. For more information, see [Boundary creation \(Run screen\) \(page 210\)](#) and [Boundary editing \(Field Manager\) \(page 211\)](#).

Guidance lines and patterns

With a steering assistance feature, your vehicle can be set to drive on guidance lines and patterns. This improves the accuracy of planting, applications and harvesting. The types of lines are:

- **AB line:** A straight line that begins at point A. After driving the direction of the line path, you end the line at point B. See [AB guidance line creation \(Run screen\) \(page 213\)](#).
- **A+ line:** A straight line that you begin with point A and choose the direction you want the line to draw.
- **Curve:** A curved line begins when you tap a button to start recording the line path and then drive in a curved direction. The line ends when you tap a button to stop recording the line path. See [Curved line creation \(Run screen\) \(page 215\)](#).

The types of patterns are:

- **Headlands:** An area you can create by recording your beginning point and stopping the recording when you are finished. You have the option to create an infill pattern of straight or curved lines. See [Headland and infill pattern creation \(Run screen\) \(page 216\)](#).
- **Pivots:** A circular area you create by recording your beginning point and stopping recording when you are finished. See [Pivot pattern creation \(Run screen\) \(page 223\)](#).

Landmarks

You create landmarks to indicate productive and non-productive areas, as well as items that you want the application to warn the driver about. Landmarks can be:

- Lines
- Points
- Areas

For more information, see

- [Landmark line creation \(Run screen\) \(page 229\)](#)
- [Landmark point creation \(Run screen\) \(page 229\)](#)
- [Landmark area creation \(Run screen\) \(page 230\)](#)
- [Landmark editing \(Field Manager\) \(page 231\)](#)

Tasks, activities and coverage

A task is a set of information that includes:



- One or more activities being completed in a field (such as planting, spraying, and so on)
- A map layer showing the activity's coverage on the field

The Precision-IQ field application stores field activities related to each unique operation and field combination together as a task. By using tasks, you do not have to continually configure fields that you frequently use.

For more information, see:

- [Tasks \(page 200\)](#)
- [Coverage logging \(page 203\)](#)

Add a field

1. At the **Home** screen, tap .
 2. Enter a name for the field and then tap .
- The system saves the field name and its location.

To work with the field, see [Preparing for operation \(page 196\)](#).

Select a field

To work with a field to work within it, you select it. When you add a field, it is selected automatically.

If you have multiple fields, you can select a field from:

- The point on the map at the **Home** screen.
- The list of fields.

Select a field through the map

The points on the map () of the **Home** screen indicate fields you have created. Tap the point that represents the field.

Select a field from the list

The outlines on the map of the **Home** screen indicate fields you have created.

1. At the **Home** screen, tap . A list of fields you previously created displays.
2. To search for a field, tap in the search area and enter the partial or complete name of the field.

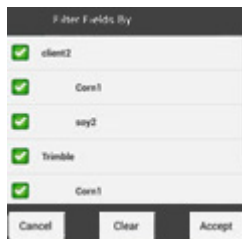

3. Deselect (uncheck) the options you do not want to see and tap **Accept**. The Fields list now shows fields associated with the client and/or farm that you left checked.
4. Tap the name of the field to select it.

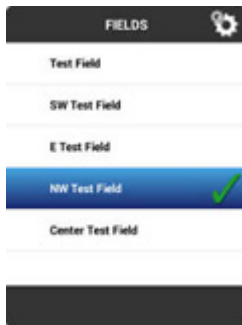

Note – A field that has a check mark but is NOT highlighted is a previously selected field.

Enter a field (*Run* screen)



Before you can enter a field in the **Run** screen, you must:

- Set up a positioning service that is working. See [GNSS receiver settings \(page 88\)](#).
- Set up a vehicle. See [Vehicle setup \(page 114\)](#).
- [Select a vehicle \(page 119\)](#)
- [Implement setup \(page 168\)](#).
- [Add an ISOBUS implement \(page 169\)](#), [Add a serial variable rate implement \(page 173\)](#) or [Add a custom-setup implement \(page 177\)](#).
- [Select an implement \(page 182\)](#).
- [Add a field \(page 160\)](#).
- [Select a field \(page 161\)](#).

Choose a field to enter



You can enter a field you currently have selected or one that is not currently selected.

Currently selected field

To enter a field that is currently selected, tap   . The **Run** screen displays.

Field not currently selected

To enter a field not currently selected:

1. At the **Home** screen, the map shows points () where your fields are located. Tap the  that represents the field you want to enter. (For a map to display on the **Home** screen, you must have a updated GNSS connection.)
2. A popup displays with the field name and two buttons.

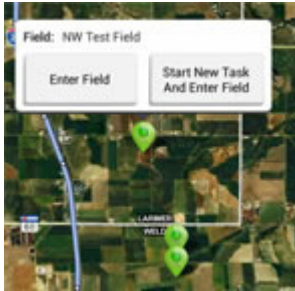

3. To enter the field without beginning a new task, tap **Enter Field**.
4. To start a new task, tap **Start New Task and Enter Field**. The **Run** screen displays.

Run screen

The text and buttons displayed on your **Run** screen depend on:

- Whether you are using a guidance / steering system or manual guidance
- Other features you are using
- How your Precision-IQ field application is set up

Edit a field (Field Manager)

1. Tap  to open the Field Manager. Field Manager opens to the Field Overview section. The map in the Field Manager shows the selected field with details, including:
 - Current vehicle position
 - Active pattern
 - Active boundary
 - Inactive boundaries



Field Item	Explanation
Field Name	You can optionally change the field name. Tap in the text box.
Client Name (optional)	The client is the customer for whom the work is being done. Client name is blank unless you import it or manually enter it here.
Farm Name (optional)	The farm is a collection of fields. Farm name is blank unless you import it or manually enter it here.
	Removes the field and all related data from the Precision-IQ field application.
ACTIVE PATTERN	The currently active pattern, and what implement type and width were used to create the pattern. To make a different pattern active, tap GUIDANCE PATTERNS .
TOTAL FIELD AREA	The calculated area of the selected field.
PRODUCTIVE AREA	Total field area minus the non-productive area.
NON-PRODUCTIVE AREA	The calculated area of the Non-productive area landmark features in the selected field.

2. To edit the field name, tap in the Field Name text box and edit the name.
Note – To ensure your changes are saved, tap the Done key on the on-screen keyboard.
3. To associate the field to a client, tap the Client name text box and enter a name.
Note – To ensure your changes are saved, tap the Done key on the on-screen keyboard.
4. To associate the field to a farm, tap the Farm Name text box and enter the name of the farm.
Note – To ensure your changes are saved, tap the Done key on the on-screen keyboard.
5. To edit guidance patterns, boundaries, survey items, or landmarks, tap the buttons at the top of the Field Manager. See the following sections for details.
 - [Guidance pattern shifting \(Field Manager\) \(page 227\)](#)
 - [Boundary editing \(Field Manager\) \(page 211\)](#)
 - [Landmark editing \(Field Manager\) \(page 231\)](#)

6. Tap  to save the changes and close the Field Manager.

Implements

In this chapter:

Implement setup	168
Add an ISOBUS implement	169
Add a serial variable rate implement	173
Add a custom-setup implement	177
Enter implement measurements	180
Review implement summary	182
Select an implement	182
Edit an implement	183
Delete an implement	183
Add a control channel	184
Modify a control channel	185
Remove a control channel	186
Prescriptions	187

Implements can be added, edited and deleted at the Implement setup panel.

You must select an implement before you can enter the *Run* screen.

Implement setup

Use the Implement setup panel to select, add, edit, calibrate or delete an implement. Implements can be pull-type equipment or attachments for self-propelled equipment.

Before you set up an implement, create a vehicle. See [Add a vehicle \(page 115\)](#).

Add an ISOBUS implement



Requires Unlock – This feature requires a license unlock to set up and use. See [Upgrade or apply a license for new feature \(page 70\)](#).

ISOBUS is a set of software and hardware standards that makes possible the communication between equipment made by different manufacturers.

With ISOBUS, you can use the Precision-IQ field application to control an ISO-certified implement without an additional display. An ISO-certified implement has small computers called electronic control units (ECUs) which send signals to the Precision-IQ field application. An ISO-certified tractor has a tractor ECU (TECU) installed on it. ECUs on implements enable you to control the operation.

- With the Precision-IQ field application, using task controller functionality (an optional feature)
- With Universal Terminal, an on-screen window that opens on the Precision-IQ field application to access directly the functions provided by the ECUs

Prior to setting up the implement and Precision-IQ field application for task controller functionality:

1. Connect the display to the ISO-certified implement with ISO cabling, using the EXP-100 cable.
2. Set up the GNSS receiver to send messages to the implement. See [CAN message settings \(page 103\)](#).
3. Unlock Task Controller. See [Upgrade or apply a license for new feature \(page 70\)](#).
4. Turn on the Task Controller feature. See [ISOBUS settings \(page 76\)](#).

Note – You must have unlocked and activated the ISOBUS Task Controller feature to set up an implement for ISOBUS. See and [ISOBUS settings \(page 76\)](#).

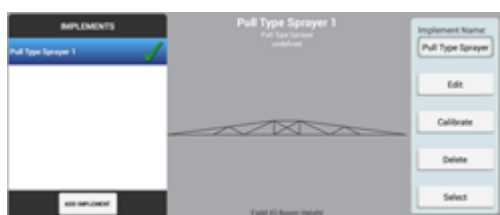

1. At the **Home** screen, tap . The Implement setup panel displays.





Tap **ADD IMPLEMENT**.

2. The *Select Implement Type* screen displays.
3. Tap **ISOBUS**. The system retrieves the information from all connected ECUs and lists them.
4. Tap **Select ISOBUS ECU**. The system displays a list of the ECUs available.
5. Tap the ECU you want to set up.

6. Tap . The system begins communicating with the ECU to collect information. When data transfer is complete, the system will notify you with a message on the screen.
7. At the Implement setup panel, tap **Edit**. The *Summary* screen displays, showing the information obtained from the ECU. Any incomplete information shows red error text. Complete the settings on each tab and section as needed.

Tab / Section	
OPERATION	The system chooses the operation based on information from the ECU.
IMPLEMENT / TYPE	Choose the type of implement you are setting up.
NAME	The system enters a name that you can edit if you wish.
MEASUREMENTS	The ECU sends some measurements to the system. Enter any missing measurements.
APPLICATION CONTROL	The system creates an application channel from information sent by the ECU. To edit channel information, press and hold the channel name and then tap Modify .
APPLICATION CONTROL CHANNEL / TYPE	<ul style="list-style-type: none"> • Name: To edit the name, tap in the entry box. • Control Type: This information is sent from the ECU, so there is no need to edit it. • ISO Implement Data: This information is sent from the ECU, so there is no need to edit it. • Material Type: Choose the type of material.
APPLICATION CONTROL CHANNEL / SETTINGS	<ul style="list-style-type: none"> • Rate Control: Tap  to toggle rate control on or off. • Rate Snapping: Tap  to toggle on or off. Due to pump constraints, liquid flow is generally inconsistent with the information on the Precision-IQ field application. By enabling this option, you will have a steadier reading of the applied rate. If you are within the allowable error, you will see the applied rate just show your target rate. This option is available if Rate Control is on. • Section Control: Tap  to toggle section control on or off. This option is available if

Tab / Section	
	<p>Section Control is on.</p> <ul style="list-style-type: none"> Number of Sections: The ECU has sent the system the number of sections. This option is available if Section Control is on.
APPLICATION CONTROL CHANNEL / WIDTH	The ECU has sent the system the width of each section.
APPLICATION CONTROL CHANNEL / LATENCIES	<ul style="list-style-type: none"> On Latency: The number of seconds it takes for the system to reach the correct rate after it has switched on. Off Latency: The number of seconds it takes for the system to turn off after it has switched off. Apply On Latency to Boundary: Tap  to toggle on or off. When on, compensates for hardware delays. On = The system determines when to switch on so that application can begin as soon as the boundary is crossed. Off = The system switches on when the boundary is reached. Any mechanical delay could leave a gap between the boundary and where the product is applied. When GPS accuracy is low, this option is recommended. Sections Off When Stopped: Tap  to toggle on or off. On = Application stops when you are not moving. Off = Application continues, even you are not moving.
APPLICATION CONTROL CHANNEL / OVERLAPS	<ul style="list-style-type: none"> Start Overlap: The distance of intentional overlap when you enter a previously applied area. The higher the number, the greater the overlapped area. End Overlap: The distance of intentional swath overlap when you exit a previously applied area. The higher the number, the greater the overlapped area. Coverage Switching Overlap: The percentage of

Tab / Section	Tab / Section
	<p>the section width for intentional overlap of a swath. The higher the number, the greater the overlapped area before the section is turned off.</p> <ul style="list-style-type: none"> • Boundary Switching Overlap: The percentage of the section width for intentional overlap of a boundary. The higher the number, the greater the overlapped area before the section is turned off.
SUMMARY	<p>When you are finished with your edits, tap  to save all information.</p>

8. After you save the information you have added or edited, the system will begin communicating again with the ECU. When the configuration is complete, the system displays a message that the device is now ready to use.

Equipment setup

As part of getting the implement ready to be controlled by Task Controller, you use Universal Terminal to set the configuration for the implement.

1. Make sure the ISO-certified implement is connected and Universal Terminal is turned on in Settings. See [ISOBUS settings \(page 76\)](#).
2. At any screen access the main menu from the [Menu bar \(page 45\)](#) by tapping .
3. Tap **Universal Terminal**. The minimized Universal Terminal displays. To maximize the widget, tap in the top right corner.
4. Follow the instructions for the equipment you are using to set the implement for using Task Controller / automatic section or rate control.

Also see:

- [Section control for ISOBUS or serial rate \(page 236\)](#)
- [Rate control \(page 235\)](#)

Add a serial variable rate implement



Requires Unlock – This feature requires a license unlock to set up and use. See [Upgrade or apply a license for new feature \(page 70\)](#).

Precision-IQ field application supports these rate controllers for automatic rate and section control using serial communication. For specific capabilities on each model, please see its documentation.

Prior to setting up the implement and Precision-IQ field application for Task Controller:

1. Connect the display using the EXP-100 cable.
2. Set up the GNSS receiver to send messages to the implement. See [CAN message settings \(page 103\)](#).

Note – To set up and use any of these implements, you must have purchased and unlocked the variable rate control feature. See .

Manufacturer	Supported models
Berthoud	EC Tronic
Hardi / Evrard	Regulor 6
Kuhn / Blanchard	REB
Rauch / Kuhn	Quantron A, Quantron E2
Sulky	Vision
Vaderstad	Control Station (with and without remote control)

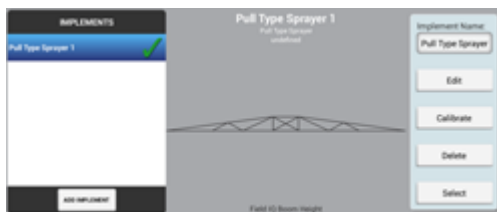

1. At the **Home** screen, tap . The Implement setup panel displays.







Tap **ADD IMPLEMENT**.

2. The *Select Implement Type* screen displays.
3. Tap **Trimble Serial VR**. The system uses the Trimble Serial Variable Rate protocol to retrieve the information from all connected serial port devices and lists them.

4. Tap **Select Serial Port Device**. The system displays a list of the serial numbers of all devices available.
5. Tap the serial number of the device you want to set up.
6. Tap the . The system begins communicating with the device to collect information. When data transfer is complete, the system will notify you.
7. At the Implement setup panel, tap **Edit**. The *Summary* screen displays, showing the information obtained from the device. Any incomplete information shows red error text. Complete the settings on each tab and section as needed.

Tab / Section	
OPERATION	The system chooses the operation based on information from the device.
IMPLEMENT / TYPE	Choose the type of implement you are setting up.
NAME	The system enters a name that you can edit if you wish.
MEASUREMENTS	The device sends some of the measurements to the system. Enter any missing measurements. See Enter implement measurements (page 180) .
APPLICATION CONTROL	The system creates an application channel from information sent by the device. To edit channel information, press and hold the channel name and then tap Modify .
OPERATION	The type of operation is received from the device.
APPLICATION CONTROL CHANNEL / TYPE	<ul style="list-style-type: none"> • Name: To edit the name, tap in the entry box. • Control Type: This information is sent from the device, so there is no need to edit it. • Serial Port Device: The serial number sent from the device. • Material Type: Choose the type of material.
APPLICATION CONTROL CHANNEL / SETTINGS	<ul style="list-style-type: none"> • Rate Control: Tap  to toggle rate control on or off. • Rate Snapping: Tap  to toggle on or off. Due to pump constraints, liquid flow is generally inconsistent with the information of the Precision-

Tab / Section	
	<p>IQ field application. By enabling this option, you will have a steadier reading of the applied rate. If you are within the allowable error, you will see the applied rate just show your target rate. This option is available if Rate Control is on.</p> <ul style="list-style-type: none"> • Section Control: Tap  to toggle section control on or off. • Number of Sections: The device has sent the system the number of sections. This option is available if Section Control is on. • Fence Row Nozzle: The device has sent information about the fence row nozzle. This option is available if Section Control is on.
APPLICATION CONTROL CHANNEL / WIDTH	The device has sent the system the width of each section.
APPLICATION CONTROL CHANNEL / LATENCIES	<ul style="list-style-type: none"> • On Latency: The number of seconds it takes for the system to reach the correct rate after it has switched on. • Off Latency: The number of seconds it takes for the system to turn off after it has switched off. • Apply On Latency to Boundary: Tap  to toggle on or off. When on, compensates for hardware delays. On = The system determines when to switch on so that application can begin as soon as the boundary is crossed. Off = The system switches on when the boundary is reached. Any mechanical delay could leave a gap between the boundary and where the product is applied. When GPS accuracy is low, this option is recommended. • Sections Off When Stopped: Tap  to toggle on or off. On = Application stops when you are not moving. Off = Application continues, even you are not moving.

Tab / Section	
APPLICATION CONTROL CHANNEL / OVERLAPS	<ul style="list-style-type: none"> • Start Overlap: The distance of intentional overlap when you enter a previously applied area. The higher the number, the greater the overlapped area. • End Overlap: The distance of intentional swath overlap when you exit a previously applied area. The higher the number, the greater the overlapped area. • Coverage Switching Overlap: The percentage of the section width for intentional overlap of a swath. The higher the number, the greater the overlapped area before the section is turned off. • Boundary Switching Overlap: The percentage of the section width for intentional overlap of a boundary. The higher the number, the greater the overlapped area before the section is turned off.
SUMMARY	<p>When you are finished with your edits, tap  to save all information.</p>

8. After you save the information you have added or edited, the system will begin communicating again with the device again. When the configuration is complete, the system displays a message that the device is now ready to use.

Also see:

- [Section control for ISOBUS or serial rate \(page 236\)](#)
- [Rate control \(page 235\)](#)

Add a custom-setup implement

Add an implement that is a custom setup if:

- You do not have application control
- You want to use virtual rate/section control
- You are using a display in addition to the TMX-2050 display
- You want to use Precision-IQ field application to guide you as you use the physical section/rate controls on the implement

1. At the **Home** screen, tap . The Implement setup panel displays.

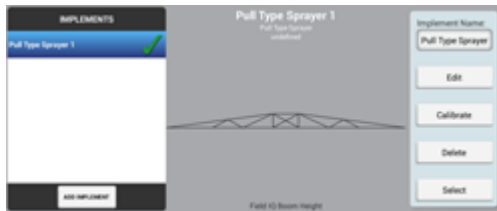





Tap **ADD IMPLEMENT**.



2. The *Select Implement Type* screen displays.

3. Tap **Custom** and then tap .

4. The first setup screen displays. With each screen, complete the settings.

Tab / Section	
OPERATION	Choose the type of operation you want to setup.
IMPLEMENT / TYPE	Choose the type of implement you are setting up.
NAME	<ul style="list-style-type: none"> • ISO Implement Data: Do not use this option for a custom setup. • Name: The system enters a name that you can edit if you wish.
MEASUREMENTS	Enter all measurements. See Enter implement measurements (page 180) .
APPLICATION CONTROL	Tap + to add a channel.
OPERATION	The type of operation is received from the device.
APPLICATION CONTROL CHANNEL /	<ul style="list-style-type: none"> • Name: To edit the name, tap in the entry box.

Tab / Section	
TYPE	<ul style="list-style-type: none"> Control Type: Select Virtual Rate Control. Material Type: Choose the type of material.
APPLICATION CONTROL CHANNEL / SETTINGS	<ul style="list-style-type: none"> Rate Control: Tap  to toggle rate control on or off. Rate Snapping: Tap  to toggle rate snapping on or off. Duse to pump constraints, liquid flow is generally inconsistent with the information of the Precision-IQ field application. By enabling this option, you will have a steadier reading of the applied rate. If you are within the allowable error, you will see the applied rate just show your target rate. This option is available if Rate Control is on. Section Control: Tap  to toggle section control on or off. Number of Sections: Choose the number of sections. This option is available if Section Control is on. Fence Row Nozzle: Choose the correct option: None, Left Only, Right Only, Both. This option is available if Section Control is on.
APPLICATION CONTROL CHANNEL / WIDTH	<p>Tap each section to enter the width.</p>
APPLICATION CONTROL CHANNEL / LATENCIES	<ul style="list-style-type: none"> On Latency: The number of seconds it takes for the system to reach the correct rate after it has switched on. Off Latency: The number of seconds it takes for the system to turn off after it has switched off. Apply On Latency to Boundary: Tap  to toggle on or off. When on, compensates for hardware delays. On = The system determines when to switch on so that application can begin as soon as the boundary is crossed. Off = The system switches on when the boundary is reached. Any mechanical delay could leave a

Tab / Section	
	<p>gap between the boundary and where the product is applied. When GPS accuracy is low, this option is recommended.</p> <ul style="list-style-type: none"> Sections Off When Stopped: Tap  to toggle on or off. On = Application stops when you are not moving. Off = Application continues, even you are not moving.
APPLICATION CONTROL CHANNEL / OVERLAPS	<ul style="list-style-type: none"> Start Overlap: The distance of intentional overlap when you enter a previously applied area. The higher the number, the greater the overlapped area. End Overlap: The distance of intentional swath overlap when you exit a previously applied area. The higher the number, the greater the overlapped area. Coverage Switching Overlap: The percentage of the section width for intentional overlap of a swath. The higher the number, the greater the overlapped area before the section is turned off. Boundary Switching Overlap: The percentage of the section width for intentional overlap of a boundary. The higher the number, the greater the overlapped area before the section is turned off.
SUMMARY	<p>When you are finished with your edits, tap  to save all information.</p>

Enter implement measurements

Before you take measurements:

- Park the vehicle on level ground.
- Make sure the implement's center is lined up with the vehicle's center.

The measurement sections show only the measurements required for the type of implement you selected.

1. Tap the button for each measurement.
2. Use the on-screen number pad to edit the measurement.

Pull-type implements

Measurement	Instructions
Hitch Type	Select how the implement connects to the vehicle: <ul style="list-style-type: none"> • Drawbar • Fixed mount
Application Width	Measure the width of the area where the implement applies material. The application calculates swath spacing using the <i>Application Width</i> and <i>Overlap/Skip</i> settings.
Hitch to Application Point	Measure the distance from the hitch pin to the boom, toolbar, and so on.
Hitch to Ground Contact Point	Measure the distance from the hitch pin to the point where the implement makes contact with the ground. This is the point that the implement rotates about.
Left/Right Offset	Measure from the center of the vehicle to the center of the implement. Select <i>Left</i> or <i>Right</i> to indicate the direction the implement is offset, when looking at the vehicle from behind. This measurement adjusts the tractor's path so that the implement is centered on the line.
Overlap/Skip	Set the amount of overlap or skip between swaths: <ul style="list-style-type: none"> • Set <i>Overlap</i> to intentionally overlay the edges of each swath by this amount. • Set <i>Skip</i> to intentionally add this amount of space between swaths.



Measurement	Instructions
Swath Width (read only)	The application calculates swath width using the <i>Application Width</i> and <i>Overlap/Skip</i> . To change <i>Swath Width</i> , edit the <i>Application Width</i> or <i>Overlap/Skip</i> .

Self-propelled equipment

Measurement	Instructions
Application Width	Measure the width of the area where the implement applies material. The display calculates swath spacing using the <i>Application Width</i> and <i>Overlap/Skip</i> settings.
Rear Axle to Application Point	Measure the distance from the rear axle to the point where the implement applies material.
Left/Right Offset	Measure from the center of the vehicle to the center of the implement. Select <i>Left</i> or <i>Right</i> to indicate the direction the implement is offset, when looking at the vehicle from behind. This measurement adjusts the tractor's path so that the implement is centered on the line.
Overlap/Skip	Set the amount of overlap or skip between swaths: <ul style="list-style-type: none"> • Set <i>Overlap</i> to intentionally overlay the edges of each swath by this amount. • Set <i>Skip</i> to intentionally add this amount of space between swaths.
Swath Width	The application calculates swath width using the <i>Application Width</i> and <i>Overlap/Skip</i> . To change <i>Swath Width</i> , edit the <i>Application Width</i> or <i>Overlap/Skip</i> .

Review implement summary

The SUMMARY section displays when you complete all of the setup and configurations steps, or when you edit an implement.

To ...	Tap ...
Save the implement with any changes you have made.	
Exit the setup without saving changes. The application will let you choose to save the changes or exit without saving.	

Save an implement

You can save complete or incomplete implements.

Save complete implement settings

1. Complete all of the implement setup and calibration steps for your operation, based on the implement type and features/plugins you have unlocked on the device.
2. When you complete the implement setup, your last step is the SUMMARY section.
3. Tap  to save the implement and return to the **Home** screen.

Save incomplete implement settings

The application allows you to save an incomplete implement and return to it later to complete.



Note – You cannot enter the run screen without a completed implement that you have selected.

1. Select an operation type, make, model and name the implement.
2. At any point after you complete the NAME section, tap . The system will ask if you want to save changes you have made. Tap **Yes** to do so.

Select an implement

Note – You can only enter the Run screen with an implement when the required implement setup and calibration steps are complete. When you change implements, make sure that all related configurations are accurate for the current operation.

To select an implement that is already set up:



1. Tap  at the **Home** screen.
2. To select an implement in the list, tap the implement.
3. Tap **Select**. The name of the implement highlights in blue and a  displays next to the name.

Note – Without a blue highlight, the  indicates an implement that was selected previously.

Edit an implement



1. Tap  on the **Home** screen. The Implement setup panel displays.
2. In the list of implements, tap the implement that you want to edit.
3. Tap **Edit**.
4. Tap the section where you want to make edits.
5. When you are finished, tap **Summary** at the top right corner of the screen. For details, see [Review implement summary \(page 182\)](#).

If any part of the setup is *Not Complete*, you can save the changes but you cannot use the implement on the **Run** screen.

6. To save your changes to the implement, tap . The **Home** screen displays.
7. To cancel / remove your edits and not change the existing profile, tap . A message displays, asking if you want to cancel without saving your changes. Tap cancel.



Delete an implement

You can delete an implement. However, when you do so, all settings associated with that implement will also be deleted.

1. Tap  on the **Home** screen.
2. Tap the implement you want to delete.
3. Tap **Delete**. A confirmation message displays for you to confirm you want to remove the implement.
4. Tap  to delete the implement.

Add a control channel



To add an application control channel:

1. Tap  on the **Home** screen. The Implement setup panel displays.
2. Tap the implement you want to work with.
3. Tap **APPLICATION CONTROL**.
4. At APPLICATION CONTROL, turn the feature on by tapping .
5. Tap  **Add**.
6. Tap **Next**.
7. The application takes you to a set of screens to set up the channel, beginning with the TYPE section.

Tap...	To...
Channel Name	The system names the channel. You can optionally change the name of the channel.





Modify a control channel

To edit an application control channel:

1. Tap  on the **Home** screen. The Implement setup panel displays.
2. Tap the implement you want to work with.
3. Tap **APPLICATION CONTROL**.
4. Tap the control channel that you want to change, then tap **Modify**.
5. Tap the button at the top of the screen for the channel setting that you want to change.
6. When you finish making changes, tap **Summary** at the top right corner of the screen.
7. If any part of the setup is not complete, you can save the changes but you cannot use the implement on the **Run** screen.
8. To save the channel and return to the Application Control section, tap . The application returns you to the Implement setup panel.
9. To exit channel setup without saving, tap . A message displays, asking if you want to cancel without saving your changes. Tap cancel.

Remove a control channel

To remove an application control channel:

1. Tap  on the **Home** screen. The Implement setup panel displays.
2. Tap the implement you want to work with.
3. Tap **APPLICATION CONTROL**.
4. Tap the control channel that you want to remove, then tap **Remove**. The system displays a confirmation message for you to confirm that you want to remove the channel.
5. Tap  to confirm the removal. Otherwise, tap  to cancel the removal.
6. When you finish making changes, tap **Summary** at the top right corner of the screen.
7. If any part of the setup is *Not Complete*, you can save the changes but you cannot use the implement on the **Run** screen.
8. To save the channel and return to the Application Control section, tap . The application returns you to the Implement setup panel.
9. To exit channel setup without saving, tap . A message displays, asking if you want to cancel without saving your changes. Tap cancel.

Prescriptions



Requires Unlock – This feature requires a license unlock to set up and use. See [Upgrade or apply a license for new feature \(page 70\)](#).

The information in a prescription is used to send target rates to the variable rate controller. Applied rates are received from the controller, and both target and applied rates appear on the screen. With prescriptions functionality, you can:

- Transfer one or more prescription files to or from the Precision-IQ field application (import or export)
- Assign a prescription to a channel
- Use a prescription to determine the rates to be applied in different areas of a field

Also see:

- [Prescriptions Manager \(page 61\)](#)
- [Importing prescriptions \(page 187\)](#)
- [Exporting prescriptions \(page 188\)](#)
- [Use a prescription \(page 242\)](#)
- [Assign a prescription \(page 241\)](#)

Importing prescriptions

Note – If you are using USB to import, make sure your USB drive has the AgGPS folder on the root, and the prescription files are in this folder.

You can import prescription files using:

- USB. See [USB data transfer \(page 64\)](#).
 - Office Sync. See [Office Sync setup \(page 106\)](#).
1. To transfer one or more prescriptions to the Precision-IQ field application, follow the steps at [Data transfer \(page 63\)](#).
 2. When transferring using USB, at the USB list on the left side of the data transfer panel, you can select the entire prescriptions folder or individual files within the folder.
 3. During the transfer, the Precision-IQ field application shows the progress of the transfer.

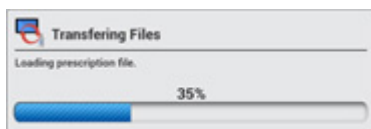

Exporting prescriptions

Note – *If you are using USB to export, make sure your USB drive has the AgGPS folder on the root.*

You can export prescription files from the Precision-IQ field application using a USB drive. See [USB data transfer \(page 64\)](#).

Materials

In this chapter:

Material list	190
Add a material	192
Edit a material	194
Delete a material	194

At the Materials setup panel, you can add and edit materials as well as calibrate material flow.

Material list

The categories and types of materials in the Materials library are listed below.

Anhydrous

The materials in this category are Anhydrous and Other.

Granular fertilizer

- Adjuvant
- Fertilizer/Lime
- Fungicide
- Growth Regulator
- Herbicide
- Insecticide
- Manure
- Nematacide
- Other
- Rodenticide

Liquid

- Adjuvant
- Fertilizer/Lime
- Fungicide
- Growth Regulator
- Herbicide
- Insecticide
- Manure
- Nematacide
- Other
- Rodenticide
- Water

Granular seed

- Barley
- Beans, Dry
- Canola
- Corn
- Corn, seed
- Cotton
- Millet
- Oats
- Other
- Peanuts
- Popcorn
- Potatoes
- Rice
- Rye
- Sorghum Grain
- Sugar Beets
- Sunflowers
- Wheat

Row crop seed

- Barley
- Beans, Dry
- Canola
- Corn
- Corn, seed
- Cotton
- Millet
- Oats
- Other
- Peanuts
- Popcorn
- Potatoes
- Rice
- Rye
- Sorghum Grain
- Sugar Beets
- Sunflowers
- Wheat

Add a material

1. At the **Home** screen, tap . The Material setup panel displays.
2. Tap **Material Library**.

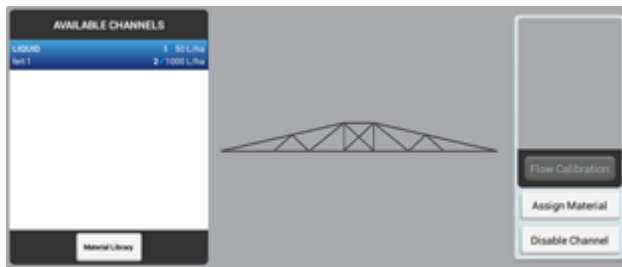

3. Tap **Add**.



4. Tap each setting and then select an option or enter information.

Tap...	To...
Material Name	Tap the text entry box and then use the on-screen keyboard to enter a name for the material.
Material Category	Select the type of material being applied: <ul style="list-style-type: none"> • Anhydrous • Granular fertilizer • Granular seed • Liquid • Row crop seed
Type	Type of material. See Material list (page 190) .
Distributed Units	Select the units to use with the selected material.
Target 1	Control the volume that the implement supplies when Rate 1 is selected.
Target 2	Control the volume that the implement supplies when Rate 2 is selected.
Rate Increment	Set rate increment. When you increment/decrement Rate 1 or Rate 2 on the Run screen, the current application rate increases or decreases by this amount.
Minimum Rate	Set the minimum rate that will be applied.
Maximum Rate	Set the maximum rate that will be applied.
Material Details (optional)	Set additional details, if needed: <ul style="list-style-type: none"> • EPA Product Number: Enter the registration number for the material from the environmental protection agency for the area, if applicable. • Manufacturer: Enter the material manufacturer's name. • Restricted Use: Tap Yes or No to record whether use of the material is restricted by local, regional, or national laws. • Posting required • Buffer Distance: Enter the buffer distance from the product label of the material. • Max Wind Speed: Enter the maximum wind speed from the product label of the material. • Notes: Enter any other notes that you want to record with the



Tap...	To...
	material.

5. Tap each setting and then select or enter a value.

Edit a material

1. At the **Home** screen, tap . The Material setup panel displays.
2. Tap **Material Library**.
3. Select the material in the list on the left-hand side of the screen and then tap **Edit**.
4. Tap each setting to make the required changes. See the settings table under the section [Add a material \(page 192\)](#).
5. Tap .

Delete a material

1. At the **Home** screen, tap . The Material setup panel displays.
2. Tap **Material Library**.
3. Select the material in the list on the left-hand side of the screen and then tap **Delete**. The system displays a confirmation screen.
4. Tap  to remove the material and  to cancel the deletion.

Operations

In this chapter:



Preparing for operation	196
Fields and guidance	197
Tasks	198
Layers	198
Adjustments during operation	198
Automatic transfer of data	199
Tasks	200
Coverage logging	203
Vehicle operation	204
Guidance patterns	207
Landmarks	228
Layers	232
Rate control	235
Section control for ISOBUS or serial rate ...	236
Universal Terminal operation	239
Prescriptions	241
On-screen widgets	244
Alerts and warnings	248

During operations while working in the **Run** screen, you can:

- Create and adjust guidance patterns
- Engage or disengage the automatic steering system
- Start a new task, include status widgets on the screen

Preparing for operation

Before you can enter a field in the **Run** screen, you must:

- Set up a positioning service. See [GNSS receiver settings \(page 88\)](#) and ensure GNSS is functioning correctly.
- [Add a field \(page 160\)](#).
- [Select a field \(page 161\)](#).
- Set up a vehicle. See [Vehicle setup \(page 114\)](#).
- Select a vehicle:
 - a. At the **Home** screen, tap . The Vehicle setup panel displays.
 - b. At the list on the left-hand side of the setup panel, tap the name of the vehicle you want to select. The application changes the list item to a blue background with white text.
 - c. To select the vehicle before performing field activities at the **Run** screen, tap **Select**. A  and the blue highlight indicates which vehicle you chose . The application indicates in the lower left-hand portion of the screen which vehicle is selected for field activities.

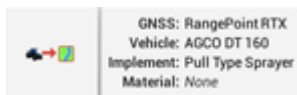



- Set up an implement. See [Add an ISOBUS implement \(page 169\)](#), [Add a serial variable rate implement \(page 173\)](#) or [Add a custom-setup implement \(page 177\)](#).
- Select an implement. See [Select an implement \(page 182\)](#).
- Select a material:
 - a. At the **Home** screen, tap . The Material setup panel displays.
 - b. Tap the material name in the list on the left-hand side of the screen.

Choose a field to enter

You can enter a field you currently have selected or one that is not currently selected.

Currently selected field

To enter a field that is currently selected, tap   . The **Run** screen displays.

Field not currently selected

To enter a field not currently selected:

1. At the **Home** screen, the map shows points (📍) where your fields are located. Tap the 📍 that represents the field you want to enter. (For a map to display on the **Home** screen, you must have a updated GNSS connection.).
2. A popup displays with the field name and two buttons.

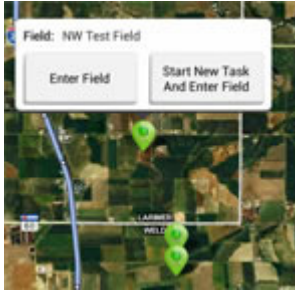

3. To enter the field without beginning a new task, tap **Enter Field**.
4. To start a new task, tap **Start New Task and Enter Field**. The **Run** screen displays.

Run screen

The text and buttons displayed on your **Run** screen depend on:

- Whether you are using a guidance / steering system or manual guidance
- Other features you are using
- How your Precision-IQ field application is set up

Fields and guidance

When you enter a field, you can create boundaries, guidance patterns and landmarks within that field. To edit any of these elements, open the Field Manager. Here you can rename your field, and include the name of your client and the name of the farm where the field is located.

See:

- [Field Basics \(page 158\)](#)
- [Field Manager \(page 56\)](#)

Tasks

While in the **Run** screen, you can log coverage of the activity you are performing in the field. As your activity is logged, applicable information is saved in a task. The information related to each task includes (but is not limited to):

- The field in which the task took place
- Time and date
- The type of operation performed

When you pause during a field activity, you can continue the same task or you can begin a new task (if you will be performing a different type of operation). At the Field Manager, you can view the history of tasks completed for each field.

See:

- [Field Manager \(page 56\)](#)
- [Tasks \(page 200\)](#)

Layers

While the system is logging your field activity, you have the option to view one layer of activity at a time. For example, you can view overlaps in coverage or the speed of your vehicle throughout the operation. You must have logging on to see layers of coverage.

See [Coverage logging \(page 203\)](#).

Adjustments during operation

While you are performing field activities, you can make adjustments to:

- [Steering adjustments \(page 206\)](#)
- [Guidance adjustments \(page 226\)](#)
- [Rate control \(page 235\)](#)
- [Section control operation \(page 237\)](#)

Automatic transfer of data

The Precision-IQ field application can wirelessly transfer information recorded during your field activities to Connected Farm and the office. This requires:

- A DCM-300 modem
- A subscription to Office Sync
- A data plan or access to Wi-Fi
- A Connected Farm account

Also see:

- [DCM-300 modem initial setup \(page 105\)](#)
- [Modem services settings \(page 78\)](#)
- [Office Sync settings, 1](#)
- [Data transfer \(page 63\)](#)

Tasks

A task consists of the combination of implement type and the selected field. The Precision-IQ field application stores field activities related to each task. By using tasks, you do not have to continually configure frequently used field profiles.

When you enter a field with the same operation and implement that you used previously, the application continues the previous task unless the *Max Task Time* has already passed.

When you change operation, implement, or field, the application automatically starts a new task.

Use the Task History section in Field Manager to:

- Open a previous task.
This is helpful if you enter a field and do not see coverage that you want to see from an earlier activity. This shows the coverage from the previous task in the field, and adds the new activity to the previous task
- Start a new task.
This is helpful if you enter a field and you see coverage from an earlier activity that you do not want to see for the current activity. When you start a new task, the application removes the previous coverage from the Run screen and saves the current activity in a new task.



Data stored in each task

The data stored in each task includes:

- The field you are working in
- Date and time for starting and stopping task
- Coverage list: The list of task coverages for the field
- Coverage overlap: The area of coverage overlap
- Height: Mean height above sea level
- Speed: The speed of the vehicle
- Material: The material being applied, if applicable
- Guidance engaged: When the automatic guidance system was and was not engaged
- Applied rate: The rate material is applied
- GPS Quality: The quality of GPS

Create a task

There are three ways you can create a task:

- **Automatically:** If you enter a field with an implement with operation that does not match any currently stored task, a new task will be created automatically.
- At the **Field Manager Task History:** Tap  to enter the Field Manager, select the task history and start a new operation. For this option, an implement must be selected. If not, the application pops up a message to tell you what is required to create the task.
- At the **Home** screen: Select . The system displays the field name along with the option to go to the field and create a new task.

Add a task (Run screen)

Tap **Start New Task** to begin a new task. The application will not show previous related map coverage layers on the **Run** screen.

Review existing tasks (Field Manager)

1. Select the field. See [Select a field \(page 161\)](#).
2. Tap  to open the Field Manager.
3. Tap **Task History**.
4. Tap the tasks on the left-hand side of the screen to review previous tasks:
 - Tap + or - to show or hide tasks for each operation.
 - Tap a specific task to select it. Each task is shown with its start and end date and time.
 - The map shows the coverage layer(s) saved for the selected task

Review existing tasks (Field Manager)

1. Select the field. See [Choose a field to enter \(page 196\)](#).
2. Tap  to open the Field Manager.
3. Tap **Task History**.

4. Tap the tasks on the left-hand side of the screen to review previous tasks:
 - Tap + or - to show or hide tasks for each operation.
 - Tap a specific task to select it. Each task is shown with its start and end date and time.
 - The map shows the coverage layer(s) saved for the selected task

Edit a task (Field Manager)

1. Add a task or select an existing task.
2. Tap **Continue Task** to add current coverage to the selected task. The display will show the previous related coverage on the Run screen.

Note – This option is only available if the implement you have selected is for the same type of operation.
3. Make sure that the *Max Task Time* is suitable.
 - a. If the implement and operation do not change, the display adds coverage to the current task until the task exceeds the *Max Task Time*.
 - b. If the *Max Task Time* is not acceptable, tap the number of days to change it.
4. Tap **Exit** to save the changes and close the Field Manager.

Coverage logging

Coverage logging:

- Records the area that you have covered when you carry out an operation, for example applying fertilizer to a field
- Allows you to view different map layers of your coverage as you are working in the field.

Manual coverage logging

To activate coverage logging, tap .

Automatic logging with engage

If your system has been configured to do so, coverage will start when your auto guidance system is engaged. Coverage will stop when auto guidance is disengaged. To turn on this capability, see [Patterns settings \(page 80\)](#).

If automatic logging is activated, you can still turn logging on or off when engaged or when disengaged by tapping .

Editing layers

To edit settings for layers, see [Edit a coverage layer \(page 234\)](#).



Vehicle operation

At the **Run** screen, tap the screen to display the vehicle position buttons. The **Engage** button shows the status of your auto guidance system as well as enables you to tap on the button to engage the system.



WARNING – Many large and sudden changes in satellite geometry caused by blocked satellites can cause significant position shifts. If operating under these conditions, auto-guidance systems can react abruptly. To avoid possible personal injury or damage to property under these conditions, disable the auto-guidance system and take manual control of the vehicle until conditions have cleared.





Vehicle position

Button	Tap to...
	Change point of view on the Run screen to an overhead view.
	Change the point of view on the Run screen to a view with the horizon.
	Zooms view in or out on the Run screen.

Auto guidance status



When the **Engage** button turns yellow, you can tap it to engage the auto guidance. After your guidance system is engaged, the button changes to green.

 **WARNING** – Auto guidance systems cannot avoid items in the field such as obstacles. Make sure you are adequately trained to operate the auto guidance system.

Indicator/Button	Auto guidance system is...
 <p>Gray Engage Disabled</p>	<p>Disabled. Enable it in the steering control panel. This is an indicator only.</p>
 <p>Red Cannot Engage</p>	<p>Does not have the proper conditions met to engage. Tap to determine the reason.</p>
 <p>Yellow Ready to Engage</p>	<p>Ready to engage (yellow). Tap to engage the auto guidance system.</p>
 <p>Green Engaged</p>	<p>Engaged (green). Indicates you are engaged on a pattern or line and are using auto guidance. Tap to disengage.</p>

Steering adjustments

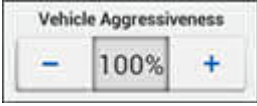
To adjust steering while performing field activities, at the **Run** screen, tap . The system displays the steering adjustment buttons.

Button	Use to...
<p>Vehicle Aggressiveness</p> 	Adjust the vehicle aggressiveness.
<p>Autosteering Enabled</p> 	Enable or disable auto steering.

Also see:

- Vehicle aggressiveness for Autopilot: [Engage aggressiveness \(page 144\)](#)
- Vehicle aggressiveness for EZ-Pilot: [Online aggressiveness calibration for EZ-Pilot system \(page 150\)](#)
- Diagnostics: [EZ-Pilot system diagnostics \(page 257\)](#), [EZ-Steer system diagnostics \(page 262\)](#)
[Autopilot system diagnostics \(page 252\)](#)

Guidance patterns

Guidance items you can place in the field from the **Run** screen include:

- Boundaries
- Straight or curved lines
- Headlands
- Pivots







After you have created guidance items, you use Field Manager to:







- Edit guidance lines, patterns and boundaries.
- Activate or deactivate boundaries, guidance lines and patterns.

To create:	To edit:	Settings/adjustments:
<p>Go to the Run screen. See:</p> <ul style="list-style-type: none"> • AB guidance line creation (Run screen) (page 213), A+ guidance line creation (Run screen) (page 214), Curved line creation (Run screen) (page 215) • Boundary creation (Run screen) (page 210) • Headland and infill pattern creation (Run screen) (page 216), Pivot pattern creation (Run screen) (page 223) 	<p>Open Field Manager. See:</p> <ul style="list-style-type: none"> • Boundary editing (Field Manager) (page 211), Guidance pattern editing (Field Manager) (page 224) 	<p>At the Run screen:</p> <p>Adjust during field activities: Guidance adjustments (page 226)</p> <p>At Settings:</p> <p>Set where the beginning of the guidance line begins in relation to the equipment. See Patterns settings (page 80).</p>

At the **Run** screen, tap  to access the buttons for creating boundaries, guidance lines and headlands and pivots.

Guidance creation buttons





Button	Tap to...
Boundary  (Red rectangle)	Record the perimeter of a field. You can use boundaries to: <ul style="list-style-type: none"> • Calculate area • Switch implement sections on and off at the edge of the field • Generate end of row warnings See Boundary creation (Run screen) (page 210) .
Headland 	Record the exterior circuit of a field. Repeat the circuit for multiple headland passes and create an infill pattern. The application uses the implement width to generate the required number of headland circuits, a headland boundary outside of the exterior headland circuit, and an infill boundary inside of the interior headland boundary. See Headland and infill pattern creation (Run screen) (page 216) .
Pivot 	Record the exterior curve of a circular field and repeat the pattern. The application uses the implement width to generate concentric circles. It also creates a pivot field boundary based on the specified distance to the pivot field edge. See Pivot pattern creation (Run screen) (page 223) .
AB Line 	Record a straight line from point A to point B. Parallel guidance lines (or swaths) will be projected multiple times on either side of the AB line. See AB guidance line creation (Run screen) (page 213) .
A+ Line 	Set a straight directional line from point A toward the selected direction (compass direction, path of travel, or heading value). Parallel guidance lines will be projected multiple times on either side of the A+ line. See A+ guidance line creation (Run screen) (page 214) .
Curve 	Record a line with curved and/or straight segments. Matching guidance lines will be projected multiple times on either side of the curved line. See Curved line creation (Run screen) (page 215) .
Set Point A 	Set the starting point of a line.
Set Point B	Set the end point of a line.

Button	Tap to...
	
Pause 	Suspend recording while you continue to drive. The application will replace the path you travel while paused with a straight line.
Record 	Begin recording a path as you drive it.
Complete 	Finishes the guidance item you have created and saves it.
Cancel 	Exits the process of creating a guidance item and does not save it.
Compass Point 	Set the heading direction for an A+ line to a compass direction. See A+ guidance line creation (Run screen) (page 214) .
Use Current Heading 	Set the heading direction for an A+ line based on the vehicle's current position. See A+ guidance line creation (Run screen) (page 214) .





Boundary creation (*Run screen*)

You can change the point on the implement's swath where you wish to record the boundary's edge:

Right, Center, or Left. To make this change, tap  before you begin driving.

1. Enter the field where you want to create the boundary. See [Enter a field \(Run screen\) \(page 162\)](#).
2. Tap . The pattern buttons display.
3. Tap  (red rectangle).
4. When you are ready to begin your boundary tap  and begin driving the perimeter of the field or area. The application:
 - Marks the point where you began recording
 - Shows the recorded path with a dashed line
5. Drive around the field until you are near your starting point.
 - If Auto-Close is on: When you reach auto-close distance, the application will connect the vehicle's current location to the starting point with a straight line and save the boundary.
 - If Auto-Close is off: Drive to the beginning point and tap . The application will connect the vehicle's current location to the starting point with a straight line and save the boundary.

To set the auto close feature, see [Patterns settings \(page 80\)](#).

6. When finished, the application makes the boundary you created active, and saves it with a unique name. The distance between swath lines is based on the width of the implement that was used to create the line.
7. To suspend recording while creating the boundary, tap . The application will replace the path you travel while paused with a straight line, from the point where you tapped  to the point where you resume recording. To resume recording, tap  or .
8. To cancel the boundary line creation, tap .
9. To edit any boundary you have created, see [Boundary editing \(Field Manager\) \(page 211\)](#).

Boundary editing (Field Manager)

1. At the **Home** screen, select the field where you want to edit the boundary. Tap  to open the Field Manager.

Or if you are at the **Run** screen, tap  to open the Field Manager for the field you are currently in.

2. At the Field Manager, tap **BOUNDARIES**.





The map and the Boundaries list show the boundaries in the selected field(s).

The application highlights the active pattern in blue on the map.

For headland boundaries (inner and outer), the list shows the implement type and width used to create each pattern.

3. To select a boundary, tap it on the map or in the list on the left-hand side of the screen.
4. To edit the pattern, use the buttons on the right-hand side of the screen.

Note – The application shows only the options that are suitable for the selected item.

Tap...	To...
Name	Use the on-screen keyboard to rename the selected item.
Resize  Note – Not available on headland boundaries.	To resize the boundary: <ol style="list-style-type: none"> a. Tap . b. Tap the text box and use the on-screen number pad to enter the distance to move the boundary. c. To shift the boundary outward (making the area larger), tap Expand. d. To shift the boundary inward (making the area smaller), tap Contract to shift the boundary inward (making the area smaller). e. Tap . The application saves a copy of the pattern with a new name at the new position.
Delete 	Remove the selected pattern.

5. To save the changes and close the Field Manager, tap .



Also see [Field Manager \(page 56\)](#).

Boundary activation/deactivation (Field Manager)

You can activate or deactivate boundaries in a selected field.

1. At the **Home** screen, select the field where you want to edit the boundary. Tap  to open the Field Manager.

Or if you are at the **Run** screen, tap  to open the Field Manager for the field you are currently in.







2. Tap **BOUNDARIES**.
3. Tap on the boundary in the list on the right-hand side.
4. Tap  (red) to activate an inactive boundary.
5. Tap  (black) to de-activate an active boundary.

Also see [Field Manager \(page 56\)](#).

AB guidance line creation (*Run screen*)



With AB lines, you define the start and end points.



Note – *The application uses the implement width to project swaths for the master line. Active lines project swaths in either direction based in the width used to create the line.*

1. Enter the field where you want to create the line. See [Enter a field \(Run screen\) \(page 162\)](#).
2. Tap . The pattern buttons display.
3. Tap .
4. Tap  to set the beginning of the line. The application:
 - Marks on the map where you tapped .
 - Shows a straight dashed line between the A point and the vehicle's current location.
5. To complete the line and close the controls, tap .
6. To save the line, tap . The distance between swath lines is based on the width of the implement that was used to create the line.
7. To cancel the AB line creation, tap .

A+ guidance line creation (*Run screen*)



With A+ lines, you define a point on the line and the direction the line is heading.

1. Select a vehicle, implement and field. See [Select a field \(page 161\)](#).
Note – The application uses the implement width to project swaths for the master line.
2. Enter the field where you want to create the line. See [Enter a field \(Run screen\) \(page 162\)](#).
3. Tap . The pattern buttons display.
4. Tap . The application changes to overhead view if you were in trailing view. The A point is set at the vehicle's current location. The A+ line controls appear in the center of the screen.
5. Select the direction you want for the A+ line.
6. To set the direction of the line, you can do any of the following:

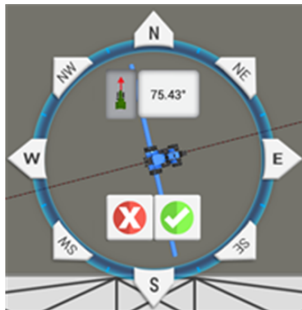





- To use the direction that the vehicle is facing as the heading, tap .
- To use the on-screen number pad to enter an exact heading, tap the number.
- To use a cardinal (N, S, E, W) or ordinal (NE, SE, SW, NW) direction, tap that direction on the compass (.



The application saves the line. The distance between swath lines is based on the width of the implement that was used to create the line.

7. To accept the line and direction and close the controls, tap . The application saves the line. The distance between swath lines is based on the width of the implement that was used to create the line.
8. To cancel the line creation, tap .









Curved line creation (*Run* screen)

1. Enter the field where you want to create the boundary. See [Enter a field \(Run screen\)](#) (page 162).
2. Tap . The pattern buttons display.
3. Tap .
4. When you are ready to begin the line tap . The application:
 - Marks your starting point on the map, at the point where you tapped record.
 - Shows the recorded path with a dashed line between the starting point and the vehicle's current location.
5. To create a straight line as part of your curved line, tap  and then tap  again.
6. When you are at the end of the line, tap .
7. To cancel the line creation, tap .

Headland and infill pattern creation (*Run* screen)

1. Select a vehicle, implement and field. See [Select a field \(page 161\)](#).

Note – The application uses the implement width to place the headland boundary, space the circuits and project guidance lines for the pattern.

2. Tap    to enter the field.
3. Tap . The pattern buttons display.
4. Tap . The headlands options display.
5. If the number of circuits is not correct, edit the number you want to create by tapping the number and entering the correct amount.
6. Optionally, select the type of infill pattern you want by tapping the correct button (AB, A+ or curve).
7. Tap  and begin driving the perimeter of the field. The application:
 - Marks the position you were at when you tapped record. You can tap  and then  again, as required.
 - Shows the recorded path with a dashed line.
 - The controls for the infill line (if any) appear below the headland recording controls.
8. If you are using an infill pattern, create the line for your infill pattern. See instructions for the type of line you are creating:
 - [AB guidance line creation \(Run screen\) \(page 213\)](#)
 - [A+ guidance line creation \(Run screen\) \(page 214\)](#)
 - [Curved line creation \(Run screen\) \(page 215\)](#)
9. Continue driving around the field until you are near your starting point.
 - If Auto-Close is on: When you reach auto-close distance, the application will connect the vehicle's current location to the starting point with a straight line and save the pattern.
 - If Auto-Close is off: Drive to the beginning point and tap . The application will connect the vehicle's current location to the starting point with a straight line and save the pattern.

To set the auto close feature, see [Patterns settings \(page 80\)](#).
10. When finished, the application:
 - a. Saves the headland pattern with a unique name (for example, HL01).

- b. Generates an inner boundary and an outer boundary based on the recorded path and the width of the implement. The headland boundaries are saved with a unique name related to the headland (for example, HL01 inner boundary and HL01 outer boundary).
- c. Generates an infill swath based on the number of circuits selected and the width of the implement. The infill swath is saved with a unique name related to the headland (for example, DefaultInfillSwath).



11. To cancel the pattern creation, tap  .

Infill pattern shift

To shift the infill pattern, complete the following steps.

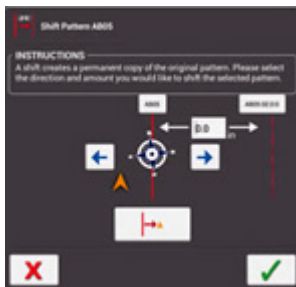
1. At the **Run** screen, open the Field Manager by tapping .
2. Tap **GUIDANCE PATTERNS**.
3. In the list of patterns, tap to select the infill pattern you want to shift, and tap **Activate**.
4. Tap **Shift**. The Shift Pattern tool displays.



5. Tap  to shift the pattern left or tap  to shift the pattern right.
6. In the entry box, enter the distance you want to shift the pattern.
7. Tap  to save the shift.
8. The shifted pattern is saved with a new name.
9. Tap the headland circuit pattern to select it, and tap **Activate**.
10. Tap **Infill**. The Infill Selection list displays.



11. Tap . The All Guidance Lines list displays.

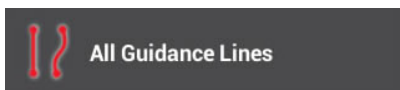

12. Tap to highlight all the infill patterns (including the shifted pattern you just created) you want to associate with the headland pattern you activated.
13. Tap . The Infill Selection list displays again.



14. Highlight the shifted swath and tap .
15. The shifted infill is now activated along with the headland swath.
16. Tap **Boundaries**. Activate the inner headlands boundary.
17. Tap **Exit** to closes the Field Manager.
18. Verify that the shifted infills are now shown and can be used for guidance.

Change the infill pattern

Note – This process assumes you have an existing headland and an infill pattern has been created.

1. Select a vehicle, implement and field. See [Select a field \(page 161\)](#).

Note – The application uses the implement width to place the headland boundary, space the circuits and project guidance lines for the pattern.

2. Tap    to enter the field.

If you need to create a new infill pattern to change to, go to step 3.

If you have an existing infill pattern you want to change to, go to step 4.

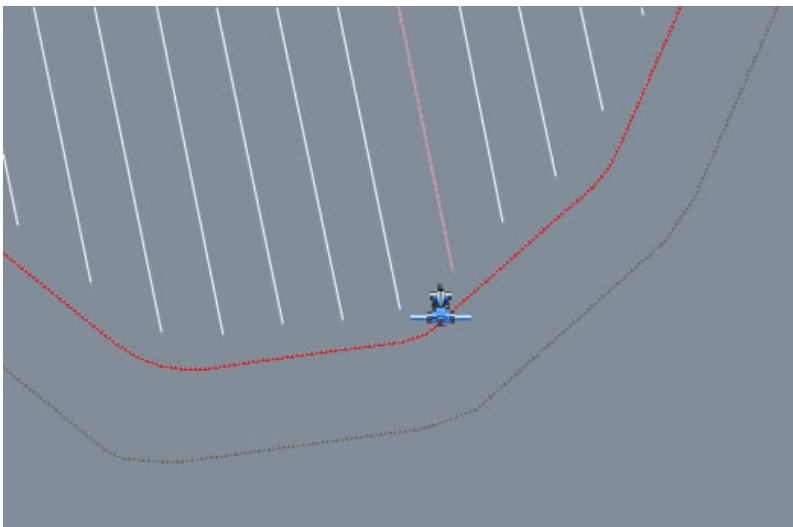

Note – If the system has been turned off, when you enter the field you will only see the headland on the **Run** screen and not the infill pattern.

3. At the **Run** screen, create a new guidance line to use as the infill pattern. See [AB guidance line creation \(Run screen\) \(page 213\)](#) or [A+ guidance line creation \(Run screen\) \(page 214\)](#).

Note – This new guidance line is automatically made active by the system, which deactivates all other guidance patterns, including the headland you are working with.

4. Open the Field Manager by tapping .

5. At the **Guidance Patterns** tab:
 - a. Highlight the headland circuit pattern you want to work with and tap **Activate**. (This is not necessary if you want to change to an existing line and did not need to create a new one in step 3.)
 - b. Tap **Infill**. The Infill Selection list displays. This lists the infill pattern that is currently assigned to use with the headland.



- c. Tap .

The All Guidance Lines list displays. This lists all guidance lines that have been created for this field that are within the headland boundary.

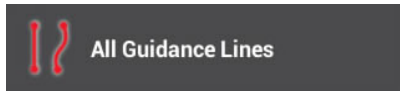

- d. Tap to highlight the guidance lines you want to associate with the headland (including the new guidance line you created in step 3).

Tap . The Infill Selection list displays again.



- e. At the Infill Selection list, highlight the guidance line you want to change to and tap . This assigns the guidance line to the headland.

6. Tap **Boundaries**. In the Boundaries list on the left-hand side, tap the inner boundary of the headland, then tap **Activate**.

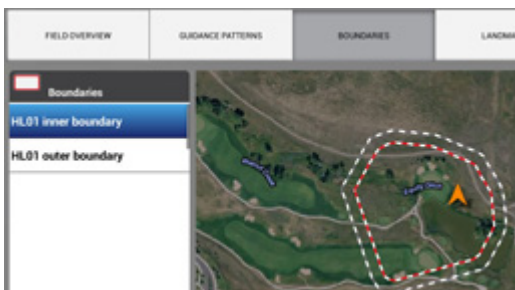





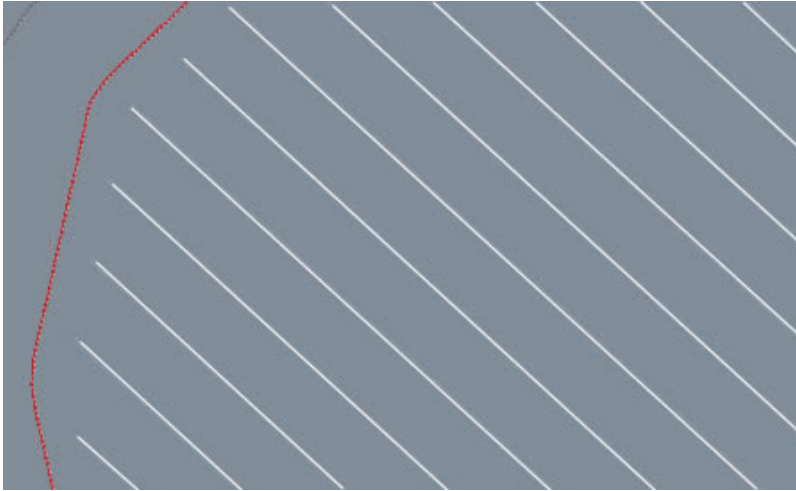

7. Exit the Field Manager by tapping **Exit**.

The new infill pattern will show in the inner boundary of the headland.



Pivot pattern creation (*Run screen*)

1. Enter the field where you want to create the pivot. See [Enter a field \(Run screen\) \(page 162\)](#).
2. Tap . The pattern buttons display.
3. Tap .
4. Tap  and begin driving the outer perimeter of the field. The application:
 - Marks your starting point on the map, at the vehicle's location when you tapped record.
 - Shows the recorded path with a dashed line.
5. Drive at least 50 feet on an outer tower rut and then tap .
6. Enter the distance to the Pivot Field Edge and tap .
7. When finished, the application:
 - Saves the pivot pattern with a unique name (for example, P01).
 - Generates a pivot boundary based on the recorded path and the width of the implement. The pivot boundary is saved with a unique name related to the headland (for example, P01 Boundary).
 - Makes the pivot boundary active.
8. To cancel the pivot creation, tap .

Guidance pattern editing (Field Manager)

1. At the **Home** screen, select the field where you want to edit the boundary. Tap  to open the Field Manager.



Or if you are at the **Run** screen, tap  to open the Field Manager for the field you are currently in.

2. Tap **GUIDANCE PATTERNS**. The map and the Patterns list show the patterns in the selected field.
3. Tap the pattern you want to edit.

The pattern must be active before you can edit it. If the pattern is not active, tap  (red) to make it active.

4. The application highlights the active pattern in blue on the map.
5. If you have chosen a headland, you can change the number of circuits in a headland.
6. Tap  to resize the pattern you have chosen.





Or for a pivot pattern, tap  .

7. Edit the size of the pattern and tap  .
8. To cancel the change, tap  .
9. To exit Field Manager, tap  .

Also see [Field Manager \(page 56\)](#).

Pattern activation/deactivation (Field Manager)

You can activate or deactivate patterns in a selected field. To engage your auto guidance system on a line, pattern or headland, it must be active.



1. Tap  to open the Field Manager. Field Manager opens to the Field Overview section.
2. Tap **GUIDANCE PATTERNS**.
3. Tap on the line, headland or pivot area in the list on the right-hand side.
4. To activate:
 - An inactive pattern, tap  (red).
 - An inactive guidance line, tap  (red).
5. To de-activate:
 - An active pattern, tap  (black).
 - An active guidance line, tap  (black).

Also see [Field Manager \(page 56\)](#).

Guidance adjustments

To adjust guidance while performing field activities, at the **Run** screen, tap . The guidance adjustment buttons display.

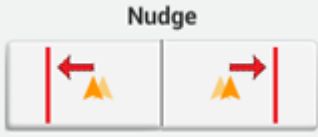
Note – These adjustments are removed if you enter a new task. Your system may also be set up to remove these adjustments with a power cycle. See [Steering and guidance settings \(page 83\)](#) for these settings.



Buttons	Use to...
<p>Nudge</p> 	<p>Temporarily move the vehicle left or right depending on the direction you chose. .</p> <p>To set the increment that nudge moves, see Steering and guidance settings (page 83).</p>
<p>Remark</p> 	<p>Temporarily move the pattern to the vehicle's current location.</p> <p>For information on re-mark settings, see Steering adjustments (page 206).</p>
<p>Implement Draft Correction</p> 	<p>Move the implement back on the guidance line if the implement is physically drifting offline in the field. The value between the arrow buttons indicates the amount of distance for the correction.</p> <p>To set the increment that implement draft correction moves, see Steering and guidance settings (page 83).</p>

Guidance pattern shifting (Field Manager)

1. At the **Home** screen, select the field where you want to edit the boundary. Tap  to open the Field Manager.

Or if you are at the **Run** screen, tap  to open the Field Manager for the field you are currently in.

2. Tap **GUIDANCE PATTERNS**.





3. Tap the pattern you want to edit. If the selected pattern is active, tap  (black) to make it inactive. If the selected pattern is not active, tap  (red) to make it active.

Note – If you activate a pattern that was created with a different implement width, the application will prompt you to shift the line for the new width or keep the original position.

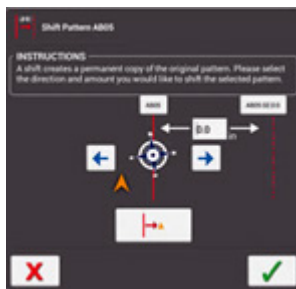
4. If you have chosen a headland, you can change the number of circuits in a headland.

5. Tap . The Shift Pattern tool displays.



6. Tap the left or right arrow to indicate the direction you want to shift the pattern.
7. Tap  to shift the pattern to the vehicle's current position, or you can enter the amount you want to shift the pattern.
8. To make the change, tap . The system creates a copy of the original pattern with the shift change.
9. To cancel the change, tap .
10. To exit Field Manager, tap .

Landmarks





When you are in the **Run** screen, you can place field items in the field, including:

- Lines, such as fences
- Points, such as trees
- Areas, such as ponds

After you have created landmarks, you can edit them and assign them to categories using Field Manager. See [Landmark editing \(Field Manager\) \(page 231\)](#).









At the **Run** screen, tap  to access the controls for creating landmark points, lines and areas.

Landmark buttons









Button	Tap to...
Point 	Place a point indicator on the field map marking a point. Available types: <ul style="list-style-type: none"> • Generic (such as a gate, riser, tile inlet, water trough, well) • Rock • Pest (insects, weeds) • Obstacle (hole, tree, hazard)
Line 	Record a line marking a landmark. Available types: <ul style="list-style-type: none"> • Generic (such as border, drip tape, gate, path, road) • Obstacle (cable, ditch, fence, hazard, pipe, river, stream, terrace, trees)
Area 	Record a shape marking a landmark. Area landmarks are not used to switch sections on and off. Available types: <ul style="list-style-type: none"> • Generic • Pest • Obstacle
Non-Productive Area 	Record a shape marking a landmark. Non-productive area landmarks can be used to switch sections on and off. Available types: <ul style="list-style-type: none"> • Generic (such as clover, exclusion, grassed waterway, slough, waterway)

Button	Tap to...
	<ul style="list-style-type: none"> • Obstacle (hazard, hole, lagoon, pond, rocks, tree) • Pest (disease, weed)

Landmark point creation (*Run* screen)

1. Select a vehicle, implement and field. See [Select a field \(page 161\)](#).
2. Tap    to enter the field.
3. Tap  .
4. Tap . The application places a marker at the vehicle's current location, based on the recording point.
5. To edit or rename landmarks you have already created, go to Field Manager. For instructions, see [Field Manager \(page 56\)](#).
6. To record a different type of landmark by default, or to change the point on the vehicle/implement used to indicate the location of the landmark, tap **Change landmark settings**.
7. To close the landmark buttons, tap  .









Landmark line creation (*Run* screen)

1. Select a vehicle, implement and field. See [Select a field \(page 161\)](#).
2. Tap    to enter the field.
3. Tap  .
4. Tap the line button .
5. Tap . The application draws a dashed line beginning at the vehicle's current location, based on the recording point.
6. Drive to the end of the line you want to record and then tap  again.
7. To discard a path that is being recorded but has not been saved, tap . The path recorded so far is not saved.
8. To start over, tap the button for the feature again.

9. To edit or rename landmarks you have already created, go to the Field Manager. For more information, see [Field Manager \(page 56\)](#).
10. To record a different type of landmark by default, or to change the point on the vehicle/implement used to indicate the location of the landmark, tap **Change landmark settings**. For more information, see [Field Manager \(page 56\)](#).
11. To close the landmark buttons, tap .

Landmark area creation (*Run screen*)

Follow the steps below to create a productive or non-productive area. Non-productive areas can be used to switch sections off when you use section control.



1. Select a vehicle, implement and field. See [Select a field \(page 161\)](#).
2. Tap    to enter the field.
3. Tap .
4. Tap  or .
5. Tap the record button . The application places a marker at the vehicle's current location, based on the recording point.
6. Drive around the area you want to record and then tap the record button again.
7. To close the landmark controls, tap .
8. To discard the recorded path and close the controls, tap . The path recorded so far is not saved.
9. To start over, tap the button for the feature again.
10. To edit or rename landmarks you have already created, see [Landmark editing \(Field Manager\) \(page 231\)](#).
11. To record a different type of landmark by default, or to change the point on the vehicle/implement used to indicate the location of the landmark, see [Field Manager \(page 56\)](#).

Landmark editing (Field Manager)

At the Field Manager, you can edit any landmarks you have created in the **Run** screen.

1. Open the [Field Manager \(page 56\)](#).
2. Tap **Landmarks**. The map and the Landmarks list show recorded landmark items including:
 - Points
 - Lines
 - Areas
 - Non-productive areas
3. To select a landmark, tap it on the map or in the list on the left-hand side of the screen.
4. Use the buttons on the right-hand side of the screen to edit the landmark.

Note – The application shows only the options that are suitable for the selected item.

Tap...	To...
Name	Rename the selected item.
Category 	Change the classification of a point, line or area landmark. Options are: <ul style="list-style-type: none"> • Generic • Obstacle <p>Note – To identify a point more specifically, change the name of the point.</p>
Convert 	Tap to: <ul style="list-style-type: none"> • Change an area to a non-productive area. • Change a non-productive area to an area.
Delete 	Remove the selected landmark from the screen.

5. To exit Field Manager, tap  .

Layers

These map layers for coverage are recorded for each task:

- Coverage Overlap
- Speed
- Height
- GPS Quality
- Offline Distance
- Guidance Engaged
- Applied Rate

You can view and edit layers. See:

- [View coverage layers \(page 232\)](#)
- [Edit a coverage layer \(page 234\)](#)

View coverage layers

To view a layer of coverage during field operations:

1. Make sure you are logging coverage. You will see the coverage in the **Run** screen behind your implement if coverage logging is on.

To turn on coverage logging, tap . Or, if you already have automatic coverage logging when you engage, tap the engage button.

See [Mapping settings \(page 77\)](#) to set automatic coverage logging.

2. Tap .
3. The current layer being shown slides out to the right.



4. To change the type of layer, tap the current layer button (at the top). The list of Available Layers

displays.

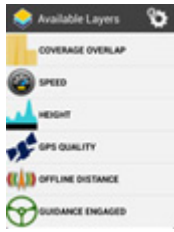

5. Tap the layer you want to see on screen.



Edit a coverage layer

To edit a coverage layer:

1. Tap .
2. The current layer being shown slides out to the right.



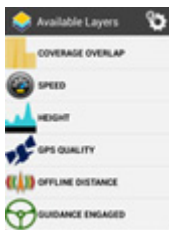

3. Tap the current layer button (at the top). The list of Available Layers displays.



4. Tap  button. The edit panel for available layers displays.



5. Change the settings of the layer to better meet your needs:
 - Auto scale
 - Steps
 - Color scheme
6. Tap  to save your changes or  to cancel your changes.

Rate control



Requires Unlock – This feature requires a license unlock to set up and use. See [Upgrade or apply a license for new feature \(page 70\)](#).

Precision-IQ field application provides automatic rate control for a supported implements that are either ISO-certified or can be controlled by Trimble's serial rate protocol.

Note – For ISOBUS, you must be connected to an ISO-certified implement that has been set up. See [ISOBUS settings \(page 76\)](#) and [Add an ISOBUS implement \(page 169\)](#).

Note – To use the Trimble protocol for serial rate, you must be connected to a supported implement that has been set up. See [Add a serial variable rate implement \(page 173\)](#).

At the **Run** screen, tap  to open the Rate Control widget. Tap the widget again to maximize it.

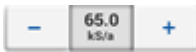
Button	Explanation
	Tap either the target rate 1 or target rate 2 to set the rate for application.
	To change the rate for either target rate, tap the - or + buttons. Optionally, tap the middle where the rate value is. Use the on-screen keyboard to enter the rate you want.

Section control for ISOBUS or serial rate



Requires Unlock – This feature requires a license unlock to set up and use. See [Upgrade or apply a license for new feature \(page 70\)](#).

Automatic section control can be used with supported ISOBUS-certified or serial rate controlled implements. With automatic section control, Precision-IQ field application turns sections on or off based on boundaries, exclusion zones and overlaps.



Note – To use Task Controller section control, you must have unlocked the feature with a valid passcode, turned on the feature in the settings. See [Upgrade or apply a license for new feature \(page 70\)](#)

Note – For ISOBUS, you must be connected to an ISO-certified implement that has been set up. See [ISOBUS settings \(page 76\)](#) and [Add an ISOBUS implement \(page 169\)](#).



Note – To use the Trimble protocol for serial rate, you must be connected to a supported implement that has been set up. See [Add a serial variable rate implement \(page 173\)](#).

Buttons for section control

At the **Run** screen, the on-screen master switch button is available for controlling sections.

Button State	Explanation
 Gray with "No" graphic	When the implement's master switch is off, the on-screen master switch is gray and not active. Precision-IQ field application's task controller cannot control sections.
 Yellow	The implement's master switch is on and the task controller is ready to control sections. All sections are off.
 Green	The implement's master switch is on. The task controller is controlling sections.

When the on-screen master switch button is green, you also have the option in the Rate Control widget to turn sections from automatic mode (based on boundaries and so on) to manual mode, with all sections on.

Button	Explanation
 Auto Auto	When activated, the task controller controls sections based on boundaries, exclusion zones and overlaps.
 Man Manual	When activated, all sections are on regardless of boundaries, exclusion zones and overlaps.



Also see:

- [ISOBUS settings \(page 76\)](#) and [Add an ISOBUS implement \(page 169\)](#)
- [Add a serial variable rate implement \(page 173\)](#)

Section control operation

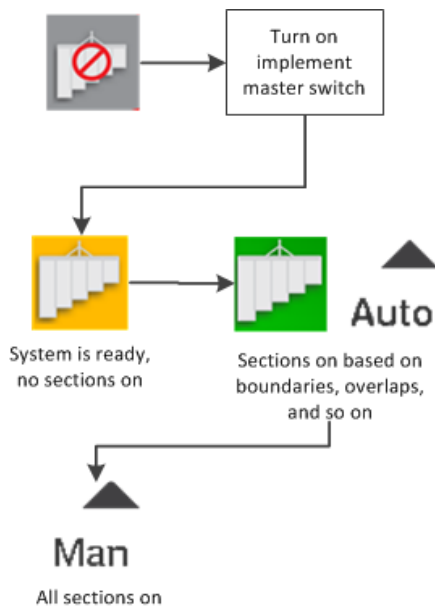
To operate section control for a supported implement that is either ISO-certified or can be controlled by Trimble's serial rate protocol, use the on-screen master switch button and auto/manual buttons.





1. Turn on the implement's master switch. The on-screen master switch button changes from gray  to yellow . Sections are still off.
2. Tap the yellow on-screen master switch button . The button changes to green

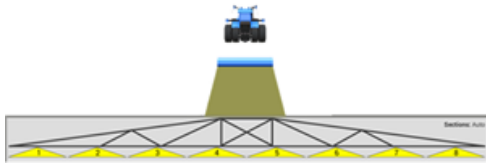

The system is now automatic mode, and sections will turn on and off based on boundaries, exclusion zones and overlaps. At the bottom of the screen, the status of sections being open or closed are shown.



3. To turn all sections on, tap the manual control button **Man** in the Rate Control widget. 
4. To change back to the automatic mode, tap the automatic control button **Auto** in the Rate Control widget. 

Also see:

- [ISOBUS settings \(page 76\)](#) and [Add an ISOBUS implement \(page 169\)](#)
- [Add a serial variable rate implement \(page 173\)](#)

Universal Terminal operation



Requires Unlock – This feature requires a license unlock to set up and use. See [Upgrade or apply a license for new feature \(page 70\)](#).

To use Universal Terminal, make sure:

- An ISO-certified implement is connected.
- You have a Universal Terminal unlock that has been applied. See [Upgrade or apply a license for new feature \(page 70\)](#).
- You have turned on the Universal Terminal feature in settings. See [ISOBUS settings \(page 76\)](#).

In the Precision-IQ field application

At the Run screen

1. At the [Run screen \(page 51\)](#), open the ISOBUS widget by tapping  and selecting Universal Terminal.
2. The Universal Terminal widget displays in a smaller version which only shows data and does not allow you to control the implement.



To increase the size of the minimized Universal Terminal widget, touch the upper right corner of the widget and hold. Arrows display on all sides of the widget. Touch and drag an arrow to increase the widget's size.

3. Tap the upper right corner of the Universal Terminal widget to maximize it. The Universal Terminal expands to full screen.

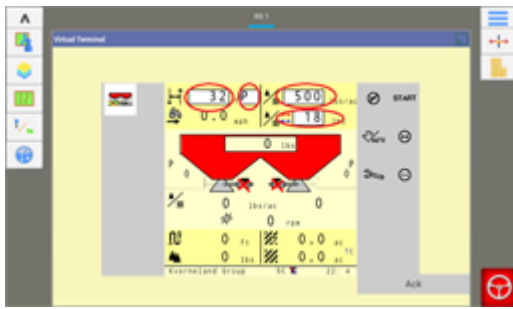

At the full-screen view, you can control the implement using Universal Terminal.

4. To minimize Universal Terminal to only show data, tap the upper right corner.

On the Menu bar



On the [Menu bar \(page 45\)](#), tap  and select Universal Terminal. The full Universal Terminal window displays.

At the Launcher screen

At the [Launcher screen \(page 47\)](#), tap . The Universal Terminal window displays.

Delete previous data

Data loaded from previously used ECUs will take up storage space. To remove this data from the Precision-IQ field application:

1. At the maximized Universal Terminal, tap .
2. Next to Delete ISO Data, tap **Delete**.
3. Tap .
4. The system removes all previous data.

Prescriptions



Requires Unlock – This feature requires a license unlock to set up and use. See [Upgrade or apply a license for new feature \(page 70\)](#).



At the **Run** screen, tap  to open the Prescriptions Manager. You can use the Prescriptions Manager to assign a prescription to a channel.

Also see:



- [Prescriptions Manager \(page 61\)](#)
- [Importing prescriptions \(page 187\)](#)
- [Exporting prescriptions \(page 188\)](#)
- [Assign a prescription \(page 241\)](#)
- [Use a prescription \(page 242\)](#)







Assign a prescription

Before you can assign a prescription, you must:

- Have a field selected. See [Select a field \(page 161\)](#).
- Have a channel set up. See [Add an ISOBUS implement \(page 169\)](#), [Add a serial variable rate implement \(page 173\)](#) or [Add a custom-setup implement \(page 177\)](#).

To assign a prescription:

1. Make sure you have a field selected.
2. At the **Run** screen, tap . The Prescriptions Manager displays.
3. In the Enabled Channels list on the left, tap the channel you want to assign the prescription to.
4. On the right, tap Prescription File Name. The Precision-IQ field application displays a list of prescription files that are available for the field you selected.
5. Tap the prescription file you want and tap .
6. Tap **Next**.
7. Tap Column Name. The list of column names displays.
8. Tap the column you want to use, then tap .

9. Tap Column Units, then tap either gal/a or L/ha. Tap .
10. Tap **Next**.
11. Optionally, tap Lead Time and enter the number of seconds (0 - 10). Tap .
12. Tap When outside Prescription and tap one of the following: Close, Last Rate or Default Rate. Tap .
13. Tap Default Rate and enter the rate. Tap .
14. If you have completed the information, tap **Finish**.
15. If you need to change previous information, tap **Back**.
16. To save your entries, tap .
17. To discard your entries, tap .

Also see:



- [Prescriptions Manager \(page 61\)](#)
- [Importing prescriptions \(page 187\)](#)
- [Exporting prescriptions \(page 188\)](#)
- [Use a prescription \(page 242\)](#)

Use a prescription

Before you can use a prescription, you must:

- Have a field selected
- Assign the prescription to a channel

To use a prescription, complete the following steps.

1. Make sure you have a field selected.
2. At the **Run** screen, tap . The rate control adjustment buttons display.
3. To begin using the prescription, tap . The other buttons will become gray and cannot be tapped unless you stop using the prescription.
4. To stop using the prescription, tap .

Also see:

- [Prescriptions Manager \(page 61\)](#)
- [Importing prescriptions \(page 187\)](#)
- [Exporting prescriptions \(page 188\)](#)
- [Assign a prescription \(page 241\)](#)

On-screen widgets

Widgets are software gadgets on the screen that can provide functionality control, information and status on the **Run** screen during field activities.

There are two types of widgets:

- Status widgets: Provide information only and do not control any function
- Control widgets: Enable you to control a function, and may include status information

For some widgets, you can choose to display or not display them.

Access widgets

To access the list of widgets available on your Precision-IQ field application:

1. At the **Run** screen, tap .
2. To display all widgets, tap **Add All Widgets**.
3. To remove all widgets, tap **Remove All Widgets**.

Minimize/maximize, resize

Some widgets can be maximized from their normal minimized size. To maximize a widget, tap the upper right corner of the widget. To make it smaller, tap the same upper right corner.

Other widgets can be re-sized to a customized size. To make a widget larger, touch the upper right corner of the widget and hold. Arrows display on all sides of the widget. Touch and drag one of the arrows to resize. When you are satisfied with the size, remove your finger. The following widgets can be re-sized:

- [Position status \(page 246\)](#): On-screen lightbar, compass, digital compass and swath number
- [Speed status \(page 247\)](#)
-

Move a widget

You can position some widgets on the screen where it makes sense for you. The position on the screen where you have chosen to display each widget is saved and associated with your user profile. That way, the next time you use the application, the widgets are where you previously placed them.

To move a status widget around on the screen:

1. Touch the widget and keep your finger on the screen.
2. Drag the widget with your finger. A grid displays on the screen.

3. After you have moved the widget where you want it, remove your finger.

Remove a widget

To remove a widget from the **Run** screen:

1. Touch the widget and keep your finger on the screen. A grid displays on the screen.
2. Drag the widget with your finger to the upper right corner. A trash can icon with the word "Remove" will display.



3. Drag the widget onto the trash can. You will no longer see the widget on the screen.

Area status

Area	
Field Area	0.00 m ²
Productive Area	0.00 m ²
Total Boundary Area	N/A
Task Coverage Area	0.00 m ²
Coverage %	N/A
Total Volume Applied	

Area status:

- Area of the field
- Productive area: Total field area minus the unproductive areas
- Total boundary area: Total of the area within the active boundaries of the field
- Task coverage area: The amount of coverage in the field
- Percent of coverage: The amount of coverage over the productive area multiplied by 100
- Total volume applied

Position status

The following status widgets on the **Run** screen indicate your position.

On-screen lightbar for auto guidance



The on-screen lightbar provides the status of where the vehicle is in relation to the guidance line. When the vehicle is perfectly on the guidance line, the value in the center is 0 and the background color is green.

The center of the lightbar represents your position. As your vehicle's position moves farther from the line, the farther the highlighted arrows will be from the center of the light bar.

As the vehicle moves farther from the guidance line, the numerical indicator shows the distance from the guidance line and the highlight color changes from green, to yellow, to red.

Position

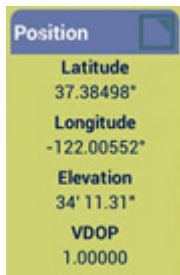

Your current position's:

- Latitude
- Longitude
- Elevation
- VDOP

Compass



The direction in which you are traveling.

Digital compass



28.5°

The degrees of the angle you are traveling.

Swath number



Swath 0

The number of the swath guidance line you are currently following.

Speed status



0.0 mph

The speed status widget indicates the speed at which you are traveling.

Alerts and warnings

The Precision-IQ field application will display warnings and alerts, depending on your features and the situation. For example, warnings and alerts will display regarding:

- Loss of GNSS coverage
- Using auto guidance and:
 - The vehicle is approaching a tight turns or the end of a row
 - The system detects the steering wheel is being used
- A lack of interaction with the display after a specific amount of time

This list is not comprehensive, rather a few examples of alerts and warnings.

End of row warning

If you are following a guidance line, when you begin approaching the end of a row, an End of Row warning displays.



Also see [Steering and guidance settings \(page 83\)](#).

Tight turn warning

When you are approaching a tight turn, the system displays a tight turn warning.



To customize your settings for tight turn warnings (including the angle of the turn and how soon the warning displays before the turn), see [Patterns settings \(page 80\)](#).

Diagnostics / troubleshooting

In this chapter:

Diagnostics	250
Precision-IQ field application	251
Autopilot system diagnostics	252
DCM-300 modem status	256
EZ-Pilot system diagnostics	257
DCM-300 modem diagnostics	260
EZ-Steer system diagnostics	262
GNSS and xFill technology status	266
GNSS diagnostics	268
ISOBUS diagnostics	273
Office Sync Diagnostics	274
System diagnostics	275
TM-200 Module diagnostics	276

This chapter covers information about the status of equipment and services, as well as troubleshooting and diagnostics information.

Diagnostics

Diagnostics has two sections:

- The left side menu lists products and services active on the display.
- The right side shows information about the item you selected on the menu.

Tap the menu items on the left-hand side of the screen to access the diagnostic sections you want to view.

Precision-IQ field application

This section describes some possible issues with the TMX-2050 display, possible causes, and how to solve them. Please read this section before you contact technical support.

The display does not turn on.

Possible cause	Solution
External power is too low.	Check: <ul style="list-style-type: none"> • The charge on the external power supply • The fuse if applicable If required, replace the battery.
Internal power is too low.	Check the charge on the internal batteries and replace if required. Ensure battery contacts are clean.
External power is not properly connected.	Check: <ul style="list-style-type: none"> • That all power connections are seated properly • For any broken or bent pins
There is a faulty external power cable.	Try a different cable. Check pin outs with a multimeter to ensure internal wiring is intact.

The display is not responsive.

1. Hold down the power button for 20 seconds.
2. After the display has shut down, press the power button again to power on the display.

The map is not visible on the *Home* screen.

If your system has a DCM-300 modem and has no map on the **Home** screen, check for:

- Possible cable disconnection
- Weak signal bars. See [DCM-300 modem diagnostics \(page 260\)](#).
- All cables are connected securely.
- The status of GNSS. See [GNSS notification button \(page 46\)](#) and [GNSS diagnostics \(page 268\)](#).

Autopilot system diagnostics

You can use diagnostics for AutoPilot to:

- View the degree of the steering angle being given by the navigation controller and the actual degree of angle.
- Calibrate:
 - Manual override sensitivity
 - Vehicle system aggressiveness
 - Line approach aggressiveness
 - Engage aggressiveness
 - Proportional steering gain (P gain)
 - Roll calibration
 - Make incremental adjustments to a pattern using the nudge increment tool
- View:
 - Vehicle roll and yaw
 - Navigation controller orientation
 - IMU parameters
 - Sensor settings
- Set the NavController to output NMEA messages.

Steering performance for Autopilot system

1. At the Diagnostics panel, tap **Performance** under Autopilot.
2. Tap **Steering**.



Button/Control	Explanation
System Feedback, Angle Desired	The degree of the steering angle command being given by the navigation controller.
System Feedback, Angle Actual	The degree of the steering angle that is actually occurring.
Vehicle System Aggressiveness	How aggressively the vehicle responds to cross track error.
Line Approach Aggressiveness	Controls how fast the guidance system attempts to steer the vehicle onto the current guidance line. See Line acquisition (page 143) for more information on calibrating.
Engage Aggressiveness	Controls how aggressively the vehicle initially engages the automatic guidance system. See Engage aggressiveness (page 144) for more information on calibrating.
P Gain	Balances rapid steering response and stability. See Proportional steering gain (page 137) for more information on calibrating. Note – This setting is not available for certain vehicle types.
Nudge Increment	This function is for advanced users to test the systems response to cross track error. While driving the vehicle online, tap the left or right button to move the line. Observe the response of the guidance system and adjust as necessary.
Engage 	Use to engage the system in the diagnostics screen. For more information on the engage button, see Vehicle operation (page 204) .

Sensor performance for Autopilot system

1. At the Diagnostics panel, tap **Performance** under Autopilot.
2. Tap **Sensors**.

Button/Control	Explanation
VEHICLE ORIENTATION	Graphically indicates the roll and yaw settings. The yaw value is the heading error for the system in reference to the heading of the guidance swath.
CONTROLLER ORIENTATION	Orientation of the controller as entered by the user.
MANUAL OVERRIDE SENSITIVITY	Sets the level the voltage must reach before the guidance system disengages. The voltage must also drop below that level before automated steering can be engaged again. You can calibrate this control here or at the Vehicle setup panel. For instructions, see Manual override sensitivity calibration (page 129) .
IMU PARAMETERS	The raw voltage reading from the accelerometer and gyroscopes in the navigation controller.
SENSORS	The raw voltage of all connected sensors.

NMEA messages

Before you can setup NMEA output, you must turn on NMEA capability in settings. See [Steering and guidance settings \(page 83\)](#).

To set the NavController to output NMEA messages:

1. At the Autopilot Diagnostics screen, tap **Performance** under Autopilot.
2. Tap the **Advanced** tab.
3. In the TAP SETTINGS section, tap in the TAP entry box.
4. Enter how often you want the NMEA message to be output by the NavController and tap **GET**. Enter the value in milliseconds. 1000 milliseconds equals 1 Hz.

NMEA Message	Message Information
RawNMEAOutputIntervalGGA	Fix data including 3D location and accuracy data
RawNMEAOutputIntervalGSA	GPS dilution of precision (DOP) and active satellites
RawNMEAOutputIntervalGST	GPS pseudorange noise statistics
RawNMEAOutputIntervalVTG	Velocity made good
RawNMEAOutputIntervalZDA	Date and time

5. To configure the baud rate:
 - a. Enter “RawNMEAOutputBaudRate” in the TAP entry box, then tap **GET**.
 - b. Enter the baud rate that is required by the external device.
 - c. Tap **SET**.

DCM-300 modem status

The LED lights on the DCM-300 modem indicate the status of specific signals.



Light status	Green LED indicates:	Amber LED indicates:
Solid	Power on and booting	Cellular link
Fast blinking (200 milliseconds on/off)	Poor or no GPS signal	Poor or no wireless signal
Blinking (one second on/off)	GPS signal	Wi-Fi link
Slow blinking (three seconds on/off)	N/A	Wi-Fi and cellular link

Also see:

- [DCM-300 modem diagnostics \(page 260\)](#)
- [MMX-070 Display Cabling Guide](#)
- [DCM-300 modem status \(page 256\)](#)

EZ-Pilot system diagnostics

You can use EZ-Pilot diagnostics to:

- Adjust:
 - Vehicle system aggressiveness
 - Line approach aggressiveness
 - Angle per turn
 - Free play offset
 - Manual override sensitivity
- View:
 - Vehicle roll and pitch
 - Navigation controller orientation
 - IMU parameters
 - Sensor settings

Steering performance for EZ-Pilot system

1. At the Diagnostics panel, tap **Performance** under EZ-Pilot.
2. Tap **Steering**.



Button/Control	Explanation
Vehicle System Aggressiveness	How aggressively the vehicle responds to cross track error while operating on the guidance line. See Online aggressiveness calibration for EZ-Pilot system (page 150) for more information on calibrating.
Line Approach Aggressiveness	Controls how fast the guidance system attempts to steer the vehicle onto the current guidance line. See Line acquisition

Button/Control	Explanation
	calibration for EZ-Pilot system (page 150) for more information on calibrating.
Free Play Offset	Used for adjusting the steering if the vehicle has greater free play offset steering in one direction than the other. It is to be used when the system constantly drives offset to the line and does not correct to "0" due to large tolerances(slop) in the steering components of the vehicle. Default= 0.0 inches (range=0-11.9 inches to the right or left).
MANUAL OVERRIDE SENSITIVITY	Sets the level of resistance on the steering wheel before the system will disengage.
Nudge Increment	This function is for advanced users to test the systems response to cross track error. While driving the vehicle online, press the left or right button to move the line. Observe the response of the guidance system and adjust as necessary.
Engage 	Use to engage the system in the diagnostics screen. For more information on the engage button, see Vehicle operation (page 204) .

Sensor performance for EZ-Pilot system

1. At the Diagnostics panel, tap **Performance** under EZ-Pilot.
2. Tap **Sensors**.



Button/Control	Explanation
VEHICLE ORIENTATION	Graphically indicates the roll and yaw settings.
CONTROLLER ORIENTATION	Orientation of the controller as entered by the user.
EXTERNAL SWITCH	Setting and state of the external switch.

DCM-300 modem diagnostics

At the Diagnostics panel, tap **DCM-300** under Connectivity.

The Network diagnostics information notifies you of the status of the network, device, cellular network and Wi-Fi network.

Network Status

Item	Explanation
Modem	Connecting, Connected, Disconnected
Cellular	<ul style="list-style-type: none"> • Network Name: The name of the network you are connected to • Signal Strength: Strength of signal to DCM-300 modem • Roaming Status: Whether you are roaming or not. Yes, No.
Internet	<ul style="list-style-type: none"> • Status: Disconnected, Connected • CF.com: Off, On (Connected Farm status)

Device Info

Item	Explanation
Serial #	Serial number of DCM-300 modem
Firmware version	Firmware version of DCM-300 modem
IMEI	Equipment number of mobile device (International Mobile Station Equipment Identity)
SIM ICCID	Subscriber Identity Module, Integrated Circuit Card Identifier
Wi-Fi Mac Address	Hardware address of DCM-300 modem

Cellular

Item	Explanation
Modem Type	GSM, CDMA
Sim Status	
Speed	Speed of cellular network

Wi-Fi Network

Item	Explanation
SSID	ID of Wi-Fi network
Speed	Speed of signal
Signal	Strength of signal
Channel	Channel of network
Security	Type of security

Also see:

- [Modem services settings \(page 78\)](#)
- [GNSS receiver settings \(page 88\)](#)
- [Connected Farm Dashboard \(page 62\)](#)

EZ-Steer system diagnostics

You can use EZ-Steer diagnostics to:

- Adjust:
 - Manual override sensitivity
 - Vehicle system aggressiveness
 - Line approach aggressiveness
 - Angle per turn
 - Free play offset
- View:
 - Vehicle roll and yaw
 - Navigation controller orientation
 - Sensor settings

Steering performance for EZ-Steer system

To access:

1. At the Diagnostics panel, tap **Performance** under EZ-Steer.
2. Tap **Steering**.

Button/Control	Explanation
Vehicle System Aggressiveness	How aggressively the system responds to cross track error while engaged on the guidance line.
Line Approach Aggressiveness	Controls how fast the guidance system attempts to steer the vehicle onto the current guidance line.
Free Play Offset	Used for adjusting the steering if the vehicle has greater free play offset steering in one direction than the other. It is to be used when the system constantly drives offset to the line and does not correct to "0" due to large tolerances(slop) in the steering components of the vehicle. Default= 0.0 inches (Range=0-11.9 inches to the Right or Left)
MANUAL OVERRIDE SENSITIVITY	Sets the level of resistance on the steering wheel before the system will disengage.

Button/Control	Explanation
Nudge Increment	This function is for advanced users to test the systems response to cross track error. While driving the vehicle online, press the left or right button to move the line. Observe the response of the guidance system and adjust as necessary.
Engage 	Use to engage the system in the diagnostics screen. For more information on the engage button, see Vehicle operation (page 204) .

Messages and fault codes

The following are warning messages that display when the EZ-Steer system becomes disengaged or there are system faults.

Disengaged warning messages

DISENGAGED!...	EZ-Steer system...
Too fast	Disengaged because the vehicle is traveling above the maximum speed.
Too slow	Disengaged because the vehicle is traveling below the minimum speed.
Too far offline	Disengaged because the vehicle has gone offline beyond the Disengage Offline value.
Manual override	Was manually disengaged when the steering wheel was turned.
Manual disengage	Was manually disengaged when the engage button was tapped, or the external foot switch or remote switch was engaged.
No GPS	Disengaged because the GPS positions have been lost.
No Corrections	Disengaged because of old or no corrections. This occurs only if Low Accuracy Warning is set to High Accuracy Only.
Unexpected Error	Disengaged due to an unexpected error with the system.

DISENGAGED!...	EZ-Steer system...
Control fault	Disengaged due to a control fault.
Controller Comms Lost	Disengaged due to a poor cable connection or a damaged cable.



System faults

Fault code:	Possible cause	Solution
01: Excessive manual override	Large number of manual overrides on one swath.	Decrease the Override Sensitivity value
02: Hardware fault	General hardware fault	Check all equipment and cables for damage.
03: Controller reset	Momentary loss of power, such as a power brownout. Controller reset unexpectedly.	Ensure no power cables are damaged and that the connectors are tight. Connect the power directly to the battery. Download the error log and send it to your local reseller.
04: Communication error	Controller failed to receive CAN messages from the EZ-Guide Plus lightbar.	Ensure the cable connection is secure and not damaged.
05: Bridge fault	Manual override sensitivity is too low. Controller is faulty.	Increase the override sensitivity value. Obtain a repair or replacement from your local EZ-Steer system reseller.
07: Broken motor cable	Motor cable is broken.	Obtain a replacement cable from your local EZ-Steer system reseller.
08: EEPROM fault	Memory error in the controller.	Contact your local reseller and request they download the error log.
09: No motor connected	The motor or motor cable is not connected to the controller.	Ensure the motor cable is connected to the EZ-Steer system motor and the system controller. Ensure all cable connections are secure and not damaged.
10: Unknown fault	Unknown fault in the system.	Contact your local reseller and request they download the error log.
11: System fault	Lightbar failed to receive messages from the	Ensure none of the cables are damaged. Ensure all connectors are tight.

Fault code:	Possible cause	Solution
	controller.	
12: Temperature too high	Controller temperature has exceeded the maximum internal operating temperature of 83 C (181F).	<p>Move the controller out of direct sunlight. Ensure the controller is well ventilated. Turn on the air conditioner and direct cool air to the controller.</p> <p>Note – <i>The internal temperature of the controller should be only 12C (22F) warmer than the external temperature.</i></p>
13: Over voltage	Power supply to the controller has exceeded 12.5 V.	<p>Ensure the EZ-Steer system is connected to a 12 V power supply.</p> <p>Note – <i>If you jump start a vehicle with a flat battery, unplug the EZ-Steer system power plug first.</i></p>
15: T2 Fault	The steering control module (SCM) is loaded with an incompatible version of firmware.	Check with your local reseller to obtain the latest version of firmware and update it.
	There are low voltage or intermittant problems with the system's power supply.	Check that there are no loose or corroded power connections, especially in the accessory plug area.
	There is a hardware fault in the EZ-Steer controller.	<ol style="list-style-type: none"> 1. If necessary, modify the power cable with an in-line fuse and hardware to a reliable power connection. 2. Ensure the vehicle electrical system is in working order and supplies enough voltage to the system. 3. If the above solutions do not work, return the EZ-Steer controller to your local reseller for service.

GNSS and xFill technology status

GNSS status is available on the [Status bar \(page 43\)](#) and the popup notification menu accessed by tapping the right side of the display bar.

Notification Button	Indicates...
 Green	GNSS connection is converged (green).
 Yellow	GNSS connection is converging (yellow).
 Red	No GNSS connection is available (red).

For more information on GNSS, see:

- [DCM-300 modem initial setup \(page 105\)](#)
- [GNSS receiver settings \(page 88\)](#)
- [GNSS diagnostics \(page 268\)](#)
- [DCM-300 modem diagnostics \(page 260\)](#)

xFill technology status

In the event of an RTK or VRS signal interruption, the display switches to xFill mode, and the xFill icon changes to a blue color.

When 5 minutes of xFill technology time remains (15 minutes have elapsed), the xFill icon changes to a red color and a warning appears on the display.

If you lose corrections from the satellite, you will go into DGPS corrections. Even if you regain exposure to the satellites, the xFill technology will not resume. Anytime xFill degrades to DGPS, the receiver must receive RTK corrections before xFill can be ready in the background again.



Additionally, if you lose any of your satellites during xFill, they will not be able to be used for the entire xFill duration of 20 minutes.

Safety feature

xFill technology estimates the drift in position. If the distance back to the original path is too large, xFill technology discontinues Fixed position, which disengages auto-steering. In this case, you can

manually steer until RTK corrections are available or switch your correction source to DGPS and engage on the lower accuracy correction source.

xFill technology status buttons

Notification Button	Indicates...
 (blue)	xFill is on (blue).
 (white)	xFill is available (white).
 (red)	xFill has less than 5 minutes of corrections (red).

For more information, see [xFill technology \(page 107\)](#).

GNSS diagnostics

At the Diagnostics panel, tap **Performance** under GNSS.



For information on GNSS settings, see [GNSS receiver settings \(page 88\)](#).



CAUTION – The GNSS antenna may experience interference if you operate the vehicle within 100 m (300 ft) of any power line, radar dish, or cell phone tower.

Solution Information

Solution Information	Explanation
Number of Satellites	Indicates number of satellites currently being used.
Correction Type	The correction service indicated at setup.
Correction Source	Modem, satellite / fast, satellite /SBAS, OmniStar HP/G2
Correction Status	Fixed, Float or x-Fill
Position Quality	Tap to change. Favor accuracy, balance quality or favor availability.

Skyplot

At the Skyplot screen, you can view the number of satellites nearest to your position.



Troubleshooting

The GNSS positioning method influences the accuracy of the GNSS position reflected in your GNSS receiver. Additionally, the following conditions can affect GNSS accuracy.

Condition	Explanation
Atmospheric effects	GNSS signals are degraded as they travel through the ionosphere. The error introduced is in the range of 10 meters. The error is removed by using a differential or RTK positioning method.
Number of satellites used	To calculate a 3D position (latitude and longitude, altitude, and time), four or more satellites must be visible. To calculate a 2D position (latitude and longitude, and time), three or more satellites must be visible. For RTK positioning, five satellites are needed for initialization. Once initialized, four or more satellites provide RTK positions. The number of visible satellites constantly changes and is typically in the range 5 through 9. The receiver can track up to 44 satellites simultaneously.
Maximum PDOP	Position Dilution of Precision (PDOP) is a unitless, computed measurement of the geometry of satellites above the current location of the receiver. A low PDOP means that the positioning of satellites in the sky is good, and therefore good positional accuracy is obtained.
Signal-to-noise ratio	Signal-to-noise ratio (SNR) is a measure of the signal strength against electrical background noise. A high SNR gives better accuracy. SNR can be degraded by other electronic equipment operating nearby, including transmitters, cell phones, or data modems. It may also be degraded by solar flares and changing atmospheric conditions.
Minimum elevation	Satellites that are low on the horizon typically produce weak and noisy signals and are more difficult for the receiver to track. Satellites below the minimum elevation angle are not tracked.
Multipath environment	Multipath errors are caused when GNSS signals are reflected off nearby objects and reach the receiver by two or more different paths.
RTK Base station coordinate accuracy	For RTK positioning, it is important to know the base station coordinates accurately. Any error in the position of the base

Condition	Explanation
	<p>station affects the position of the rover; every 10 m of error in a base station coordinate can introduce up to 1 ppm scale error on every measured baseline. For example, an error of 10 m in the base station position produces an error of 10 mm over a 10 km baseline to the rover.</p> <p>For more information about how to make sure the position of your base station is accurate, refer to the manual for your base station receiver.</p>
Multiple RTK base stations	<p>If you are using several base stations to provide RTK corrections to a large site area, all base stations must be coordinated relative to one another. If they are not, the absolute positions at the rover will be in error.</p> <p>For more information about how to use several base stations to cover your site, contact your local Trimble Reseller.</p>

Poor accuracy (multipath)

Poor accuracy can be due to GNSS signals reflecting off nearby trees and/or metal buildings and horizontal surfaces. (Reflection is also called multipath.)

To reduce multipath noise, mount the GNSS receiver so that it has a clear view of the sky. The receiver must be away from trees and large metal objects.

Intermittent loss of lock on satellite

- The receiver loses the satellite signal from time to time: Make sure that the receiver is mounted on the highest point of the vehicle and is clear of metal surfaces.
- Signal takes a long time to initialize
 - In RTK mode, longer baselines require longer initialization times. (The baseline is the distance between the base receiver and the rover receivers.)
 - Wait for the receiver to initialize or consider repositioning the base receiver to shorten the baseline. Make sure the rover receiver is in a clear area.

Loss of initialization

In RTK mode initialization can be lost when the rover receiver is close to trees or buildings and the number of satellites falls below four. Additionally, initialization may be lost if the receiver has not been tracking RTK corrections for some time.

- Move away from trees and obstructions to initialize. Once initialized, approach the obstructed area again. If the obstructions are severe, GNSS positioning may not work in that area.
- Because the GNSS satellites move, there may be times of the day when you are working in an area with obstructions.

Not tracking RTK corrections

The radio link is down or intermittent. Ensure that:

- The line-of-sight between the base and rover receivers is not obstructed.
- The rover receiver is within range of the radio.
- The radio power supply is on.

Poor signal / not receiving a clear signal

- Interference from 2-way radios

Transmitting FM 2-way radios can interfere with OmniSTAR, WAAS, and GNSS signal reception. Make sure that there is at least 1 m (3 ft) between the FM 2-way radio antenna and the receiver.

- Vehicle issues

An unshielded ignition system can cause enough noise to block reception of a differential signal. Use resistor spark plug wires on the vehicle ignition system.

An alternator can cause noise that interferes with a differential signal.

Note – Before replacing engine parts in an attempt to solve this problem, make sure that the problem is not caused by a computer or power source near the receiver. Some computers and their power sources cause noise that disrupts GNSS and satellite DGNS signals.

Possible solutions include:

- Use bypass capacitors, commonly available in automotive stores for cleaning up interference to CB and other radios. If the problem persists, shield engine components with aluminum foil.
- Relocate the antenna on the machine. Determine the optimal antenna location.
- GNSS receiver issues:
 - Mounting location: The receiver may not be picking up a clear signal due to mounting location. Mount the receiver on the centerline of the vehicle, away from any sources of interference and with a clear view of the sky.
 - Cable problems: Use an ohmmeter to check the cable. The resistance of a good cable between connector pins at each end of the cable is zero. If the cable is sound, but the problem persists, try exchanging the cable with one that you know is working. If the cable

is defective, contact your local Trimble Reseller for an RMA number (if the Trimble product is still under warranty), or to purchase a replacement cable.

- **Battery:** A Lithium-ion battery in the receiver powers the internal real-time clock. This clock enables the receiver to get an initial fix faster. The battery has a life of 7.5 years. When the battery fails, the internal clock cannot keep accurate time and the receiver may take longer to output GNSS positions. Please contact your local Trimble Reseller to get the batteries replaced. You cannot replace the battery yourself.

The receiver is not tracking any satellites.

Possible cause	Solution
The GNSS antenna does not have clear line of sight to the sky.	Ensure the antenna has a clear line of sight.
The cable between the receiver and the GNSS antenna is damaged.	Replace the cable.
The cable connections at receiver or antenna are not tightly seated, or are connected incorrectly.	Check all cable connections.

ISOBUS diagnostics

At the Diagnostics panel, tap **Task Controller/Universal Terminal** under ISOBUS.



Device tab

Display Information	Explanation
Device Name	Name of device
Device S/N	Device's serial number
Software Version	Version of ISO firmware
CAN Connection	Status of CAN connection
Pool Loaded	Yes or No. Indicates data from ECU is loaded.
ISO-TC	Task Controller data is available.
ISO-UT	Universal Terminal data is available.

Note – If ECU data does not auto-populate, it may be necessary to cycle power to the ECU.

Note – If the implement's ECU is power cycled while still in the Run screen, it is necessary to exit and re-enter the Run screen before being able to resume Task Controller.

Recording and saving CAN logs

1. At the Diagnostics panel under System, tap **Logging/CAN Logs**.
2. For the appropriate port, tap  to begin the recording.
3. Tap  again to stop recording.
4. Insert a USB drive into a USB socket of the Precision-IQ field application.
5. Tap  to transfer the logs to the USB drive.

Office Sync Diagnostics

At the Diagnostics panel, tap **Office Sync** under Connectivity.

Office Sync wirelessly transfers files between the display and Connected Farm and the office. As files are created from field activities, Office Sync places these in an outbox. At the time you have specified for transfers to occur, Office Sync sends the files from the outbox in the display to the office.

At Office Sync diagnostics, the following information displays:

Section	Explanation
Current State	<p>The state of sending or receiving files using Office Sync. Options include:</p> <ul style="list-style-type: none"> • Disconnected: Display is not authorized for Office Sync • Authenticating: Display is checking for permission to use Office Sync • Ready for file transfer: Display is connected to the Internet and Office Sync is enabled • Checking for files: Display is checking for updates to be transferred • Receiving files (and percentage): Display is receiving files from the office. Percentage indicates the progress of the download. • Sending files (and percentage): Display is sending files to the office. Percentage indicates the progress of the send.
Outbox	A list of files waiting to be sent.
Sent	A list of files that have been transferred.
Received	The list of files that have been received from the office.

Also see:

- [Modem services settings \(page 78\)](#)
- [Office Sync data transfer \(page 65\)](#)

System diagnostics

At system diagnostics, you can work with logs and view the system performance.

System performance

Performance lists devices and performance details for each product or service, including firmware versions.

At the Diagnostics panel, tap **Performance** under System.

Display

Item	Explanation
Internal	Capacity of internal memory
USB	Capacity of USB currently plugged into the USB socket

Devices

Item	Explanation
Title	Title of the component
Firmware Version	Version of component's firmware
Hardware Version	Version of the component
Serial Number	Serial number of the component

TM-200 Module diagnostics

The TM-200 Module has LED lights that shows the status of connections to it.

Note – Fast LED flash is approximately 3 flashes per second. Slow LED flash is approximately 1 flash per second.

LED 1

Indicates the status of the link and traffic between the TM-200 Module port marked with



LED 2

Indicates the status of the link and traffic between the TM-200 Module port and the display.

LED 3

For future use.

LED 3 and 4 combination

Blinking between red and green indicates the TM-200 Module is either starting up or loading new firmware.

LED 4

Orange fast flash = no position

LED Indicator	Autonomous	SBAS	RangePoint RTX	OmniSTAR HP/G2
Orange solid	N/A	Autonomous, has SBAS signal	Autonomous/ DGPS, has RTX signal	Autonomous/ DGPS, has OmniSTAR signal
Orange slow flash	N/A	Autonomous, no SBAS signal	Autonomous/ DGPS, no RTX signal	Autonomous/ DGPS, no OmniSTAR signal
Green solid	Autonomous position	DGPS, has SBAS signal	Converged	Converged

LED Indicator	Autonomous	SBAS	RangePoint RTX	OmniSTAR HP/G2
Green slow flash	N/A	DGPS, no SBAS signal, using recent corrections	Unconverged	Unconverged
Green fast flash	N/A	Converged/unconverged, using old corrections	Subscription expired or other error	Converged/unconverged, using old corrections

LED Indicator	CenterPoint RTX (satellite)	CenterPoint RTX (modem)	CenterPoint VRS/RTK
Orange solid	Autonomous/DGPS, has RTX signal	Autonomous/ DGPS, connected to RTX server	Autonomous/DGPS, no CMR or RTCM3 corrections
Orange slow flash	N/A	Autonomous, no SBAS signal	Autonomous/DGPS, no RTX signal
Green solid	Converged	Converged	Fixed
Green slow flash	Not converged	Not converged	Float
Green fast flash	Converged/unconverged, using old corrections	Converged/unconverged, using old corrections	Fixed/float, using old corrections

Glossary

A -- B -- C -- D -- E -- F -- G -- H -- I -- L -- M -- N -- P -- R -- S -- T -- U -- V --
W

A

A+ line

A guidance line you define on your field. The A+ line is defined fixing a point, then heading in a direction.

AB line

A guidance line you define on your field. You set a beginning point (A) and an end point (B).

Accelerometer

A device that measures non-gravitational acceleration.

Access path

A space between your guidance lines. They can be useful if there is road (or other field feature that breaks the consistent flow of swaths) through the middle of your field.

Aggressiveness

The measure of how strongly the system makes steering changes.

Autonomous GNSS positioning

Autonomous GNSS positioning uses no corrections. The rover receiver calculates its position using only the GNSS signals it receives. This method does not have high absolute accuracy, but the relative accuracy is comparable to the other methods.

RTK GNSS positioning uses the RTK positioning method to achieve centimeter-level accuracy. To use the RTK method, you must first set up a base station. The base station uses a radio link to broadcast RTK corrections to one or more rover receivers.

B

Boundary

A line indicating the border surrounding a field.

C

CenterPoint™ RTK for radio

Positioning correction service for radio communication systems. Requires access to a base station located within a eight-mile radius (approximately) from your farm. An RTK base station sends corrections via a radio transmitter to a mobile receiver attached to your vehicle. Works well for farms within 8 miles of an established RTK base station or base station network, without line-of-sight obstructions such hilly terrain or an abundance of trees.

CenterPoint™ RTX™

Positioning correction service for satellite communication systems. Delivers GPS or GNSS enabled corrections via satellite directly to your receiver. Does not require a base station or cellular data plan. CenterPoint RTX corrections are provided on as subscription basis.

CenterPoint™ RTX™ for cellular

Positioning correction service for cellular communications. Delivers corrections via cellular network directly to your receiver. Requires a cellular data plan.

CenterPoint™ VRS™

Virtual reference station. Positioning correction service for cellular communication systems. Enables RTK (Real-Time Kinetic) corrections over a large geographic area where robust cellular data coverage is available. Provides high accuracy for guidance applications throughout the whole coverage area. Requires a cellular data plan. Uses a cellular communication modem, such as the DCM-300 or Ag3000. Relies on CORS.

Client

The customer for whom the work is being done.

Controller orientation

Correctly associate the outputs of the Autopilot controller sensors with the direction of the vehicle.

Correction service

A service which provides corrections to create a higher GPS accuracy.

CORS (Continuously Operating Reference Station) network

A network of GPS/GNSS reference stations situated within the coverage area to transmit RTK (Real-Time Kinetic) corrections to the cellular modem. The distance between the reference stations and the modem on the vehicle does not affect accuracy. CORS works well in areas with spotty RTK radio tower coverage.

Curved line

A guidance line you define on your field. You begin recording and drive until you are at the end of the curved line or segment, then stop recording.

D

DGNSS

Differential GNSS positioning. The GNSS receiver uses corrections from WAAS/EGNOS satellites or from OmniSTAR HP, XP, G2, or VBS satellites. These differential systems use special algorithms to provide differential corrections that allow the rover receiver to calculate its position more accurately. Not all corrections services support the use of GLONASS satellites in their solution.

DGPS

Differentially corrected Global Positioning System (GPS).

E

EGNOS

European Geostationary Navigation Overlay Service. An [SBAS](#) operated by the European Space Agency.

Event

A precision agriculture activity on a particular field. For example: planting seed, applying fertilizer or lime, or spraying with fungicide, herbicide or insecticide.

F

Farm

A collection of fields.

Field

Settings created in the Precision-IQ field application to represent an actual field, one or more parts of an actual field, or a group of two or more fields. Field profiles include guidance lines for steering, pivot patterns and landmarks.

Freeplay

Movement in the steering linkage through which a movement of the steering wheel will cause no change in wheel angle.

Freeplay offset

A value entered to give the control system a way to account for freeplay during guidance.

G

GLONASS

A Russian space-based satellite navigation system.

GNSS

Global Navigation Satellite System. A system of GPS US and Russian satellites that provide information about geo-spatial positioning. A GNSS receiver can determine its longitude, latitude and altitude. In the future, GNSS will also use Chinese GPS satellites.

GPS

Global Positioning System. A space-based satellite navigation system. A GPS receiver can determine its position by using GPS satellites.

GPS autonomous positioning

A mode of operation in which a GPS receiver computes position fixes in real time from satellite data alone, without reference to data supplied by a base station. Autonomous positioning is the least precise positioning procedure a GPS receiver can perform, yielding position fixes that are precise to ± 100 meters.

H

HDOP

The horizontal component of [PDOP](#).

Headland

A guidance pattern that contains straight lines within a boundary.

I

IMD

Inertial Measurement Device.

IMEI

International Mobile Station Equipment Identity. A number to identify mobile equipment. The GSM network uses this number to identify valid devices. The IMEI number has no relationship to the subscriber.

IMU

Inertial Measurement Unit. An electronic device that measures and reports on a vehicle's velocity, orientation, and gravitational forces, using a combination of accelerometers and gyroscopes.

Integrated radio

Trimble integrated radios contain a radio antenna integrated with the GNSS receiver or display in a single unit. These integrated radios receive corrections transmitted by Trimble GNSS RTK base stations.

L**Logging**

Also called coverage logging. Logging records the area that you have covered when you carry out an operation, for example applying fertilizer to a field.

License

A license enables a software feature, and is valid for an unlimited duration. A license does not need to be activated, but does need to be assigned to and delivered to a specific display. Assignment and delivery of a license occurs on the reseller portal.

M**Manual override**

Required for platforms that employ a pressure transducer for the manual override function. Change the default only if the operation of the manual override function is unacceptable.

Material

A product that is controlled by a PWM valve, Servo valve, or Rawson™ drive. You can use a planter (seed), liquid, granular seed and granular fertilizer, all of which have different setup parameters.

Multipath error

An error caused by the interference of the same signal reaching the receiver by two different paths: once via the direct path, and once via a reflection. A major cause of GPS errors.

N

NMEA standard

An electrical, hardware and data standard designed by the National Marine Electronics Association that dictates the content and format of communication between GPS receivers and other devices. NMEA messages include data that provides location and accuracy, the number of satellites being used, the dilution of precision and signal strength.

P

PDOP

Position Dilution of Precision. A calculation that takes into account the satellites that can be seen, how high they are and their bearing. The outcome of the calculation is an estimation of how prone to error your GPS position is. The lower the value, the more accurate your position. You may wish to plan your field work for periods of low PDOP. Generally, the more satellites in view, the better (lower) the PDOP.

Pivot

A guidance pattern you define for your field by recording the outer circular boundary of the pivot area and then entering a value to compute the rows within the pivot.

R

RangePoint™ RTX™

Positioning service for satellite communication systems. RangePoint RTX works with a built-in GNSS receiver. Does not require a base station or cellular data plan.

Rate switch for Field IQ

Used to select Preset Rate 1, Preset Rate 2, or Manual Rate Control.

Real Time Kinematic (RTK)

A navigation technique to improve the information received from satellite-based positioning systems. Used with GPS, GLONASS and Galileo.

Roll correction

Compensates for antenna height and static roll caused by minor variations in the navigation controller and the mounting of the GPS receiver.

Row

The individual row unit which seed comes from on the planter. This can be controlled individually as a single row section, or as a group with other rows in a multiple row section.

Corrections for satellite communication systems.

Run screen

The screen where you perform field activities.

S**SBAS**

Space Based Augmentation System. A system of Earth-based systems at points surveyed for location accuracy that measure satellites, signals and factors that can impact the signals. The SBAS then broadcasts corrections to satellite signals to improve accuracy.

Scintillation

Causes extreme fluctuations in signals that are received. Scintillation can be caused by turbulence that creates air pockets with different temperatures and densities.

Section

A number of rows or spray nozzles that are controlled by existing shut-off valve, Tru Count air clutches, or Tru Count LiquiBlock™ valves. A section can have either a single row/nozzle or multiple rows/nozzles depending on how the system is set up.

Section Control Module

Controls 12 sections/rows per module with up to 4 modules (48 module sections / rows).

Service

A service is a subscription to an application that lasts for a specific amount of time, such as one or two years. You associate a service with a specific display that can be delivered wirelessly, through a QR code included in an email or through download to a computer.

Single Input Module

The signal input module (SIM) can interface with existing equipment inputs to control on-screen buttons and features.

Singulation

The percentage of time an individual seed is placed for every intended drop.

Slew time

The amount of time that the front wheels take to move from the far left to the far right position and back.

Steering deadzone

The amount of pressure that the system must apply to the hydraulics before the wheels begin to turn.

T**TAP**

Tuning parameter for guidance algorithms.

U**Unlock**

A passcode that unlocks access to a feature or upgrade. See [Upgrade or apply a license for new feature \(page 70\)](#).

V**VDOP**

A measurement of the vertical [PDOP](#).

W**WAAS**

Wide Area Augmentation System. An [SBAS](#) operated by the US Federal Aviation Administration.

Wheelbase

The distance between the front and rear axles. On tracked vehicles, the wheelbase is exactly half the length of the track.